

Ballasts

Helvar

freedom in lighting

HELVAR

Helvar is an international lighting technologies company specialised in energy efficient components and solutions for lighting and lighting control systems. Helvar is a family-owned company established in 1921.

In addition to luminaire manufacturers, our customer base comprises electrical and lighting designers and electrical contractors. Our wide understanding of both components and lighting systems enables us to design versatile and energy efficient lighting solutions.

We serve our customers locally in over 40 countries. Our headquarters are located in Finland, as are our component product development and manufacturing operations. Our lighting control competence centre is in England. Worldwide, our customers are served by offices in eight countries and our global network of partners.

CONTROLLABLE ELECTRONIC BALLASTS

DALI & 1-10 V controllable ballasts

4-17

STANDARD ELECTRONIC BALLASTS

18-33

MAGNETIC BALLASTS

For fluorescent & HID lamps

34-53

GENERAL INFORMATION

Instructions for use, Lamp ballast compatibility

54-68

CONTROLLABLE ELECTRONIC BALLASTS



Helvar have a comprehensive range of controllable ballasts covering both analogue solutions (1-10 VDC) and solutions with DALI interfaces. All ballasts are microprocessor controlled utilizing the latest technology highlighting energy saving, quality and lighting comfort.

Helvar controllable ballasts have superior features such as:

- OCC technology: highest possible EEL=A1BAT
- Very low stand-by power
- Multi-load operations in several compact and T5 lamps
- Single/twin operation in one iDim-c ballast
- In building management systems the DALI ballasts can provide information of the energy consumption, running hours et.c. on-line and directly from the luminaire

EL-iDim / EL-iDim-c DALI BALLASTS

EL-iDim / EL-iDim-c DALI ballasts are designed for a broad range of applications from the smallest intelligent luminaires to major lighting installations in large building complexes. What's more, they offer the important advantage of enabling everything to be achieved with the same ballasts. EL-iDim / EL-iDim-c DALI ballasts are also fully compatible

with Helvar iDim sensors, the combination creating the latest high-tech innovation available to the lighting market. With out-of-box functionality, the Helvar system is moreover, easy to install and use, and maintenance costs are always kept to a minimum.

EL-sc 1-10 V BALLASTS

The fully electronic, microprocessor-controlled EL-sc ballasts offer significant performance advantages over other solutions, especially with regard to energy efficiency, lighting quality and comfort.

In addition, the EL-sc range has a multi-control feature allowing for dimming either by an analogue 1-10 VDC signal or by a contact closure (Switch-Control). This dimming method is unique in that both control methods can be used simultaneously, offering a high degree of flexibility in lighting design.

OCC™ - OPTIMUM CATHODE CONTROL

The proven OCC™ - Optimum Cathode Control technology used in Helvar EL-s, EL-sc, EL-iDim and EL-TCs electronic ballast ranges.

OCC™ ensures that the electrical parameters supplied to the lamp are always optimum, minimising system losses and maximising lamp lifetime. The achieved energy saving is considerable compared to existing ballasts on the market.



Digital DALI electronic ballasts for T5 fluorescent lamps

freedom in lighting

- Digital DALI control
- Switch-Control *
- Stand-by consumption 0.3 W
- Dimming range 1-100 % **
- Only 21 mm high
- Microprocessor controlled
- Standard & sidemount possibilities
- User friendly, quick release connectors

14-80 W 220-240 V, 50-60 Hz



A1 BAT



Lamp type	Wattage	No. of lamps	Ballast	EEI	Dimensions	Connection	Weight	Circuit power	Mains current	Lamp power
						(p. 14)	(g)	(W)	(A)	(W)
T5	14	1	EL1x14-35iDim	A1 BAT	1	1	250	17	0.08-0.07	13.7
	14	2	EL2x14-35iDim	A1 BAT	2	2	330	32.5	0.15-0.14	13.7
	14	3	EL3x14iDim	A1 BAT	2	3	310	47.5	0.22-0.20	13.7
	14	4	EL4x14iDim	A1 BAT	2	4	330	62	0.29-0.27	13.7
	21	1	EL1x14-35iDim	A1 BAT	1	1	250	23.5	0.11-0.10	20.7
	21	2	EL2x14-35iDim	A1 BAT	2	2	330	46	0.22-0.20	20.7
	24	1	EL1x24iDim	A1 BAT	1	1	250	25.5	0.12-0.10	22.5
	24	2	EL2x24iDim	A1 BAT	2	2	330	50.5	0.23-0.21	22.5
	28	1	EL1x14-35iDim	A1 BAT	1	1	250	32	0.15-0.14	27.8
	28	2	EL2x14-35iDim	A1 BAT	2	2	330	62	0.28-0.26	27.8
	35	1	EL1x14-35iDim	A1 BAT	1	1	250	39	0.18-0.17	34.7
	35	2	EL2x14-35iDim	A1 BAT	2	2	330	73.5	0.36-0.30	34.7
	39	1	EL1x39iDim	A1 BAT	1	1	250	42.5	0.20-0.18	38
	39	2	EL2x39iDim	A1 BAT	2	2	330	82.5	0.38-0.35	38
	49	1	EL1x49iDim	A1 BAT	1	1	250	55	0.25-0.23	49.3
	49	2	EL2x49iDim	A1 BAT	2	2	330	107.5	0.49-0.45	49.3
	54	1	EL1x54iDim	A1 BAT	1	1	250	59	0.27-0.25	53.8
	54	2	EL2x54iDim	A1 BAT	2	2	330	117	0.53-0.49	53.8
	80	1	EL1x80iDim	A1 BAT	1	1	250	86	0.39-0.36	80
	80	2	EL2x80iDim *	A1 BAT	2	2	365	170	0.78-0.70	80

Note: See pages 14-17 for connection diagrams and additional characteristics.

* No Switch-Control in EL2x80iDim

** Dimming range 3-100 % for EL3x14iDim & EL4x14iDim

For information on compatibility with amalgam lamps, please contact your local Helvar representative.

Dimensions	1	2
Length 'a' (mm)	360	430
Width 'b' (mm)	30	30
Height 'c' (mm)	21	21
'd' (mm)	350	420

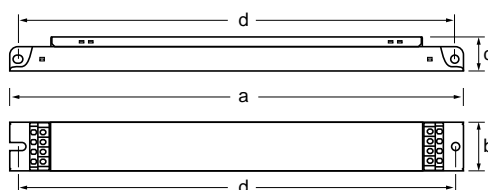

Delivery information					
Ballast	Unit package		Transportation package		
	Minimum delivery amount	Plastic binding strip	EUR pallet 1200 x 800 (pcs.)	Pallet weight (kg)	Pallet height (cm)
EL1 x iDim	10	●	980	300	40
EL2 x iDim	10	●	840	325	43
EL3 x iDim	10	●	840	325	43
EL4 x iDim	10	●	840	325	43

Right to use German patent DE19757295 of Tridonic Atco

- Digital DALI control
- Switch-Control *
- Stand-by consumption 0.3 W
- Dimming range 1-100 % ¹⁾
- Only 21 mm high
- Microprocessor controlled
- Standard & sidemount possibilities
- User friendly, quick release connectors

14-80 W 220-240 V, 50-60 Hz



A1 BAT

Lamp type	Wattage	No. of lamps	Ballast	EEI	Dimensions	Connection	Weight	Circuit power ²⁾	Mains current ²⁾	Lamp power ²⁾
							(p.14)	(W)	(A)	(W)
T5 eco	14 eco	1	EL1x14-35iDim ⁴⁾	A1 BAT	1	1	250	17	0.08-0.07	13.7
	14 eco	2	EL2x14-35iDim ⁴⁾	A1 BAT	2	2	330	32.5	0.15-0.14	13.7
	14 eco	3	EL3x14iDim ¹⁾⁴⁾	A1 BAT	2	3	310	47.5	0.22-0.20	13.7
	14 eco	4	EL4x14iDim ¹⁾⁴⁾	A1 BAT	2	4	330	62	0.29-0.27	13.7
	21 eco	1	EL1x14-35iDim ⁴⁾	A1 BAT	1	1	250	23.5	0.11-0.10	20.7
	21 eco	2	EL2x14-35iDim ⁴⁾	A1 BAT	2	2	330	46	0.22-0.20	20.7
	24 eco	1	EL1x24iDim ³⁾	A1 BAT	1	1	250	25.5	0.12-0.10	22.5
	24 eco	2	EL2x24iDim ³⁾	A1 BAT	2	2	330	50.5	0.23-0.21	22.5
	28 eco	1	EL1x14-35iDim ⁴⁾	A1 BAT	1	1	250	32	0.15-0.14	27.8
	28 eco	2	EL2x14-35iDim ⁴⁾	A1 BAT	2	2	330	62	0.28-0.26	27.8
	35 eco	1	EL1x14-35iDim ⁴⁾	A1 BAT	1	1	250	39	0.18-0.17	34.7
	35 eco	2	EL2x14-35iDim ⁴⁾	A1 BAT	2	2	330	73.5	0.36-0.30	34.7
	49 eco	1	EL1x49iDim ³⁾	A1 BAT	1	1	250	55	0.25-0.23	49.3
	49 eco	2	EL2x49iDim ³⁾	A1 BAT	2	2	330	107.5	0.49-0.45	49.3
	54 eco	1	EL1x54iDim ³⁾	A1 BAT	1	1	250	59	0.27-0.25	53.8
	54 eco	2	EL2x54iDim ³⁾	A1 BAT	2	2	330	117	0.53-0.49	53.8
80 eco	1	EL1x80iDim ³⁾	A1 BAT	1	1	250	86	0.39-0.36	80	
80 eco	2	EL2x80iDim ^{3)*}	A1 BAT	2	2	365	170	0.78-0.70	80	

Note: See pages 14-17 for connection diagrams and additional characteristics.

* No Switch-Control in EL2x80iDim

1) Dimming range 3-100 % for EL3x14iDim & EL4x14iDim

2) Maximum values at 100 % dimming level.

3) Power controlled products, no energy saving when ecolamps are used. Lamps are running over powered.

4) Current controlled products, maximum 10% energy saving achieved from declared maximum value, depending on lamp types.

For information on compatibility with amalgam lamps, please contact your local Helvar representative.

Dimensions	1	2
Length 'a' (mm)	360	430
Width 'b' (mm)	30	30
Height 'c' (mm)	21	21
'd' (mm)	350	420

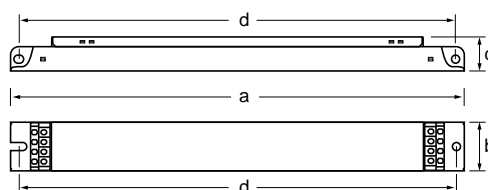

Delivery information					
Ballast	Unit package		Transportation package		
	Minimum delivery amount	Plastic binding strip	EUR pallet 1200 x 800 (pcs.)	Pallet weight (kg)	Pallet height (cm)
EL1 x iDim	10	●	980	300	40
EL2 x iDim	10	●	840	325	43
EL3 x iDim	10	●	840	325	43
EL4 x iDim	10	●	840	325	43

Right to use German patent DE19757295 of Tridonic Atco

Helvar | Data is subject to change without notice. More information at: www.helvar.com

- Digital DALI control
- Switch-Control *
- Stand-by consumption 0.3 W
- Dimming range 1-100 %
- Only 21 mm high
- Microprocessor controlled
- Standard & sidemount possibilities
- User friendly, quick release connectors

24 - 80 W 220-240 V, 50-60 Hz



A1 BAT

Lamp type	Wattage	No. of lamps	Ballast	EEL	Dimensions	Connection	Weight	Circuit power	Mains current	Lamp power
						(p.14)	(g)	(W)	(A)	(W)
T8	36	1	EL1x36iDim	A1 BAT	1	1	250	35.5	0.17-0.15	32
	36	2	EL2x36iDim	A1 BAT	2	2	330	70.5	0.32-0.30	32
TC-L	24	1	EL1x24iDim	A1 BAT	1	1	250	25.5	0.12-0.10	22.5
	24	2	EL2x24iDim	A1 BAT	2	2	330	50.5	0.23-0.21	22.5
	26	1	EL1x14-35iDim ¹⁾	A1 BAT	1	1	250	29.3	0.13	26
	26	2	EL2x14-35iDim ¹⁾	A1 BAT	2	2	330	56	0.25	26
	28	1	EL1x14-35iDim ¹⁾	A1 BAT	1	1	250	29.3	0.13	26
	28	2	EL2x14-35iDim ¹⁾	A1 BAT	2	2	330	56	0.25	26
	36	1	EL1x36iDim	A1 BAT	1	1	250	35.5	0.17-0.15	32
	36	2	EL2x36iDim	A1 BAT	2	2	330	70.5	0.32-0.30	32
	55	1	EL1x55iDim	A1 BAT	1	1	250	59.5	0.27-0.25	55
	55	2	EL2x55iDim	A1 BAT	2	2	330	119.5	0.55-0.50	55
80	1	EL1x80iDim	A1 BAT	1	1	250	86	0.39-0.36	80	
80	2	EL2x80iDim *	A1 BAT	2	2	365	170	0.78-0.70	80	

Note: See pages 14-17 for connection diagrams and additional characteristics.

* No Switch-Control in EL2x80iDim

¹⁾ To ensure stable operation of the lamp it is not recommended to dim the light level below 3 %

For information on compatibility with amalgam lamps, please contact your local Helvar representative.

Dimensions	1	2
Length 'a' (mm)	360	430
Width 'b' (mm)	30	30
Height 'c' (mm)	21	21
'd' (mm)	350	420

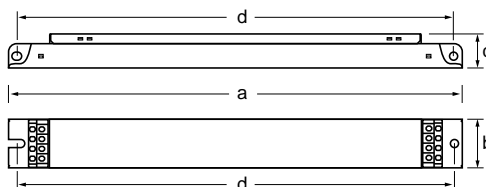

Delivery information

Ballast	Unit package		Transportation package		
	Minimum delivery amount	Plastic binding strip	EUR pallet 1200 x 800 (pcs.)	Pallet weight (kg)	Pallet height (cm)
EL1 x iDim	10	●	980	300	40
EL2 x iDim	10	●	840	325	43

- Digital DALI control
- Switch-Control
- Stand-by consumption 0.3 W
- Dimming range 3-100 %
- Multilamp operation
- Single and twin lamp operation

18 - 42 W 220-240 V, 50-60 Hz



A1 BAT

Lamp type	Wattage	No. of lamps	Ballast	EEL	Dimensions	Connection	Weight	Circuit power	Mains current	Lamp power
						(p.14)	(g)	(W)	(A)	(W)
TC-L/ TC-F	18	1	EL1/2x18/24iDim-c	A1 BAT	123x79x28	5	155	18	0.09	16
	18	2	EL1/2x18/24iDim-c	A1 BAT	123x79x28	6	155	35.5	0.16	16
	24	1	EL1/2x18/24iDim-c	A1 BAT	123x79x28	5	155	26	0.12	22
	24	2	EL1/2x18/24iDim-c	A1 BAT	123x79x28	6	155	50	0.23	22
T5c	22	1	EL1/2x18/24iDim-c	A1 BAT	123x79x28	5	155	26	0.12	22
	40	1	EL1/2x18/24iDim-c	A1 BAT	123x79x28	5	155	44.5	0.20	40
TC-DE/ TC-TE	18	1	EL1/2x18iDim-c	A1 BAT	123x79x28	5	155	20	0.09	16.5
	18	2	EL1/2x18iDim-c	A1 BAT	123x79x28	6	155	38	0.17	16.5
	26	1	EL1/2x26-42iDim-c	A1 BAT	123x79x28	5	155	28	0.13	23
	26	2	EL1/2x26-42iDim-c	A1 BAT	123x79x28	6	155	56	0.25	23.5
	26	2	EL2x26-42iDim-c	A1 BAT	123x79x28	7	176	56	0.25	25
	32	1	EL1/2x26-42iDim-c	A1 BAT	123x79x28	5	155	35	0.16	31
	32	2	EL2x26-42iDim-c	A1 BAT	123x79x28	7	176	70.5	0.32	32
	42	1	EL1/2x26-42iDim-c	A1 BAT	123x79x28	5	155	46	0.2	41.5
	42	2	EL2x26-42iDim-c	A1 BAT	123x79x28	7	176	93	0.42	43
	57	1	EL1/2x26-42iDim-c ¹²⁾	A1 BAT	123x79x28	5	155	61	0.27	56

Note: See pages 14-17 for connection diagrams and additional characteristics.

1) Tested and recommended by Helvar, not ENEC approved

2) $U_{IN} > 220 V, T_a > 18 ^\circ C$

For information on compatibility with amalgam lamps, please contact your local Helvar representative.

Dimensions	
Length 'a' (mm)	123.0
Width 'b' (mm)	79.0
Height 'c' (mm)	28.0
'd' (mm)	100.5
'e' (mm)	65.0
'f' (mm)	111.0
'g' (mm)	25.5

Delivery information					
Ballast	Unit package		Transportation package		
	Minimum delivery amount	Carton Box	Pallet 820 x 1280 (pcs.)	Pallet weight (kg)	Pallet height (cm)
EL-iDim-c	10	40	800	148	48

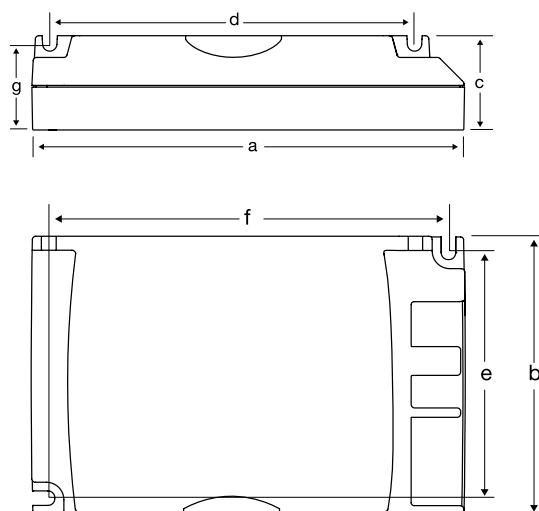

Right to use German patent DE19757295 of Tridonic Atco

Controllable (1-10 V) electronic ballasts for T5 fluorescent lamps

freedom in lighting

- Switch-Control / Analogue control¹⁾
- Only 21 mm high
- Standard & sidemount possibilities
- Dimming range 1-100 %²⁾
- Microprocessor controlled
- User friendly, quick release connectors
- Low energy consumption
- Stabilised, flickerfree light output

14-80 W 220-240 V, 50-60 Hz



A1



Lamp type	Wattage	No. of lamps	Ballast	EEI	Dimensions	Connection	Weight	Circuit power	Mains current	Lamp power
						(p.14)	(g)	(W)	(A)	(W)
T5	14	1	EL1x14sc	A1	1	8	270	17	0.08-0.07	13.7
	14	2	EL2x14sc	A1	2	9	340	31	0.15-0.14	13.7
	14	4	EL4x14sc ²⁾	A1	2	10	340	62	0.29-0.27	13.7
	21	1	EL1x21sc	A1	1	8	270	24	0.11-0.10	20.7
	21	2	EL2x21sc	A1	2	9	340	46	0.22-0.20	20.7
	24	1	EL1x24sc	A1	1	8	270	26	0.13-0.12	22.5
	24	2	EL2x24sc	A1	2	9	340	50	0.24-0.20	22.5
	28	1	EL1x28sc	A1	1	8	270	31	0.15-0.14	27.8
	28	2	EL2x28sc	A1	2	9	340	64	0.30-0.28	27.8
	35	1	EL1x35sc	A1	1	8	270	39	0.18-0.17	34.7
	35	2	EL2x35sc	A1	2	9	340	78	0.36-0.34	34.7
	39	1	EL1x39sc	A1	1	8	270	42	0.20-0.18	38
	39	2	EL2x39sc	A1	2	9	340	83	0.40-0.36	38
	49	1	EL1x49sc	A1	1	8	270	55	0.25-0.23	49.3
	49	2	EL2x49sc	A1	2	9	340	106	0.50-0.46	49.3
	54	1	EL1x54sc	A1	1	8	270	61	0.28-0.26	53.8
54	2	EL2x54sc	A1	2	9	340	118	0.53-0.49	53.8	
80	1	EL1x80sc	A1	1	8	270	88	0.41-0.38	80	

Note: See pages 14-17 for connection diagrams and additional characteristics.

1) Simultaneous lighting control by Switch-Control and Analogue control

2) Dimming range 3-100 % for EL 4x14sc

For information on compatibility with amalgam lamps, please contact your local Helvar representative.

Dimensions	1	2
Length 'a' (mm)	360	430
Width 'b' (mm)	30	30
Height 'c' (mm)	21	21
'd' (mm)	350	420

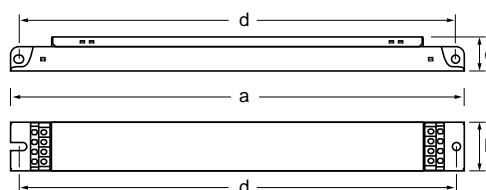

Delivery information

Ballast	Unit package		Transportation package		
	Minimum delivery amount	Plastic binding strip	EUR pallet 1200 x 800 (pcs.)	Pallet weight (kg)	Pallet height (cm)
EL1 x sc	10	●	980	300	40
EL2 x sc	10	●	840	325	43
EL4 x sc	10	●	840	325	43

Controllable (1-10 V) electronic ballasts for T5-eco fluorescent lamps *freedom in lighting*

14-80 W 220-240 V, 50-60 Hz

- Switch-Control / Analogue control ¹⁾
- Only 21 mm high
- Standard & sidemount possibilities
- Dimming range 1-100 % ²⁾
- Microprocessor controlled
- User friendly, quick release connectors
- Low energy consumption
- Stabilised, flickerfree light output



A1



Lamp type	Wattage	No. of lamps	Ballast	EEI	Dimensions	Connection	Weight	Circuit power	Mains current	Lamp power ³⁾
						(p.14)	(g)	(W)	(A)	(W)
T5 eco	14 eco	1	EL1x14sc	A1	1	8	270	17	0.08-0.07	13.7
	14 eco	2	EL2x14sc	A1	2	9	340	31	0.15-0.14	13.7
	14 eco	4	EL4x14sc ²⁾	A1	2	10	340	62	0.29-0.27	13.7
	21 eco	1	EL1x21sc	A1	1	8	270	24	0.11-0.10	20.7
	21 eco	2	EL2x21sc	A1	2	9	340	46	0.22-0.20	20.7
	24 eco	1	EL1x24sc	A1	1	8	270	26	0.13-0.12	22.5
	24 eco	2	EL2x24sc	A1	2	9	340	50	0.24-0.20	22.5
	28 eco	1	EL1x28sc	A1	1	8	270	31	0.15-0.14	27.8
	28 eco	2	EL2x28sc	A1	2	9	340	64	0.30-0.28	27.8
	35 eco	1	EL1x35sc	A1	1	8	270	39	0.18-0.17	34.7
	35 eco	2	EL2x35sc	A1	2	9	340	78	0.36-0.34	34.7
	49 eco	1	EL1x49sc	A1	1	8	270	55	0.25-0.23	49.3
	49 eco	2	EL2x49sc	A1	2	9	340	106	0.50-0.46	49.3
	54 eco	1	EL1x54sc	A1	1	8	270	61	0.28-0.26	53.8
	54 eco	2	EL2x54sc	A1	2	9	340	118	0.53-0.49	53.8
	80 eco	1	EL1x80sc	A1	1	8	270	88	0.41-0.38	80

Note: See pages 14-17 for connection diagrams and additional characteristics.

1) Simultaneous lighting control by Switch-Control and Analogue control

2) Dimming range 3-100 % for EL 4x14sc

3) Powercontrolled products, no energy saving when ecolamps are used. Lamps are running over powered.

For information on compatibility with amalgam lamps, please contact your local Helvar representative.

Dimensions	1	2
Length 'a' (mm)	360	430
Width 'b' (mm)	30	30
Height 'c' (mm)	21	21
'd' (mm)	350	420

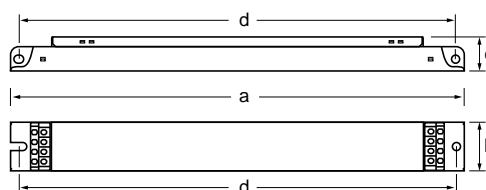

Delivery information

Ballast	Unit package		Transportation package		
	Minimum delivery amount	Plastic binding strip	EUR pallet 1200 x 800 (pcs.)	Pallet weight (kg)	Pallet height (cm)
EL1 x sc	10	●	980	300	40
EL2 x sc	10	●	840	325	43
EL4 x sc	10	●	840	325	43

Controllable (1-10 V) electronic ballasts for T8 fluorescent lamps

freedom in lighting

- Switch-Control / Analogue control ¹⁾
- Only 21 mm high
- Standard & sidemount possibilities
- Dimming range 1-100 % ²⁾
- Microprocessor controlled
- User friendly, quick release connectors
- Low energy consumption
- Flickerless light

18-70 W 220-240 V, 50-60 Hz



A1



Lamp type	Wattage	No. of lamps	Ballast	EEI	Dimensions	Connection	Weight	Circuit power	Mains current	Lamp power
						(p.14)	(g)	(W)	(A)	(W)
T8	18	1	EL1x18sc	A1	1	8	270	19	0.09-0.08	16
	18	2	EL2x18sc	A1	2	9	340	37	0.18-0.15	16
	18	4	EL4x18sc ²⁾	A1	2	10	340	72	0.33-0.30	16
	36	1	EL1x36sc	A1	1	8	270	37	0.17-0.16	32
	36	2	EL2x36sc	A1	2	9	340	71	0.33-0.30	32
	58	1	EL1x58sc	A1	1	8	270	55	0.27-0.26	50
	58	2	EL2x58sc	A1	2	9	340	108	0.50-0.46	50
	70	1	EL1x70sc	A1	1	8	270	65	0.31-0.27	60

Note: See pages 14-17 for connection diagrams and additional characteristics.

1) Simultaneous lighting control by Switch-Control and Analogue control

2) Dimming range 3-100 % for 4x18sc

For information on compatibility with amalgam lamps, please contact your local Helvar representative.

Dimensions	1	2
Length 'a' (mm)	360	430
Width 'b' (mm)	30	30
Height 'c' (mm)	21	21
'd' (mm)	350	420

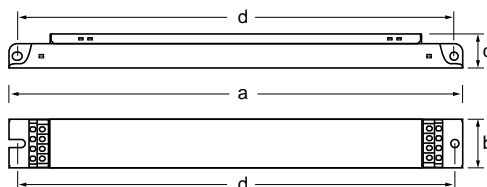

Delivery information					
Ballast	Unit package		Transportation package		
	Minimum delivery amount	Plastic binding strip	EUR pallet 1200 x 800 (pcs.)	Pallet weight (kg)	Pallet height (cm)
EL1 x sc	10	●	980	300	40
EL2 x sc	10	●	840	325	43
EL4 x sc	10	●	840	325	43

Controllable (1-10 V) electronic ballasts for compact fluorescent lamps *freedom in lighting*

- Switch-Control / Analogue control¹⁾
- Only 21 mm high
- Standard & sidemount possibilities
- Dimming range 1-100 %
- Microprocessor controlled
- User friendly, quick release connectors
- Low energy consumption
- Flickerless light

24-80 W 220-240 V, 50-60 Hz



A1



Lamp type	Wattage	No. of lamps	Ballast	EEL	Dimensions	Connection	Weight (g)	Circuit power (W)	Mains current (A)	Lamp power (W)
						(p.14)				
TC-L	24	1	EL1x24sc ²⁾	A1	1	8	270	26	0.13-0.12	24
	24	2	EL2x24sc ²⁾	A1	2	9	340	50	0.24-0.20	24
	36	1	EL1x36sc	A1	1	8	270	37	0.17-0.16	32
	36	2	EL2x36sc	A1	2	9	340	71	0.33-0.30	32
	40	1	EL1x39sc ²⁾	A1	1	8	270	44	0.20-0.18	40
	40	2	EL2x39sc ²⁾	A1	2	9	340	84	0.40-0.36	40
	55	1	EL1x55sc	A1	1	8	270	61	0.28-0.26	55
	55	2	EL2x55sc	A1	2	9	340	117	0.53-0.49	55
TC-F	80	1	EL1x80sc ²⁾	A1	1	8	270	88	0.41-0.38	80
	24	1	EL1x24sc ²⁾	A1	1	8	270	26	0.13-0.12	24
	24	2	EL2x24sc ²⁾	A1	2	9	340	50	0.24-0.20	24
	36	1	EL1x36sc ²⁾	A1	1	8	270	37	0.17-0.16	32
T5c	36	2	EL2x36sc ²⁾	A1	2	9	340	71	0.33-0.30	32
	40	1	EL1x39sc ²⁾	A1	1	8	270	43	0.20-0.18	40

Note: See pages 14-17 for connection diagrams and additional characteristics.

1) Simultaneous lighting control by Switch-Control and Analogue control

2) Tested and recommended by Helvar, not ENEC approved combination

For information on compatibility with amalgam lamps, please contact your local Helvar representative.

Dimensions	1	2
Length 'a' (mm)	360	430
Width 'b' (mm)	30	30
Height 'c' (mm)	21	21
'd' (mm)	350	420

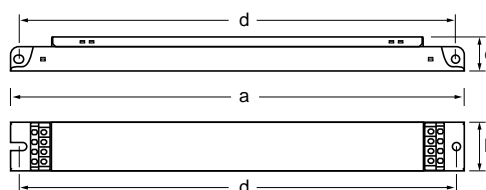

Delivery information

Ballast	Unit package		Transportation package		
	Minimum delivery amount	Plastic binding strip	EUR pallet 1200 x 800 (pcs.)	Pallet weight (kg)	Pallet height (cm)
EL1 x sc	10	●	980	300	40
EL2 x sc	10	●	840	325	43
EL4 x sc	10	●	840	325	43

Connection diagrams

EL-iDim

NOTE: All wiring to the connectors marked with a red dot (hot wires) should be as short as possible.

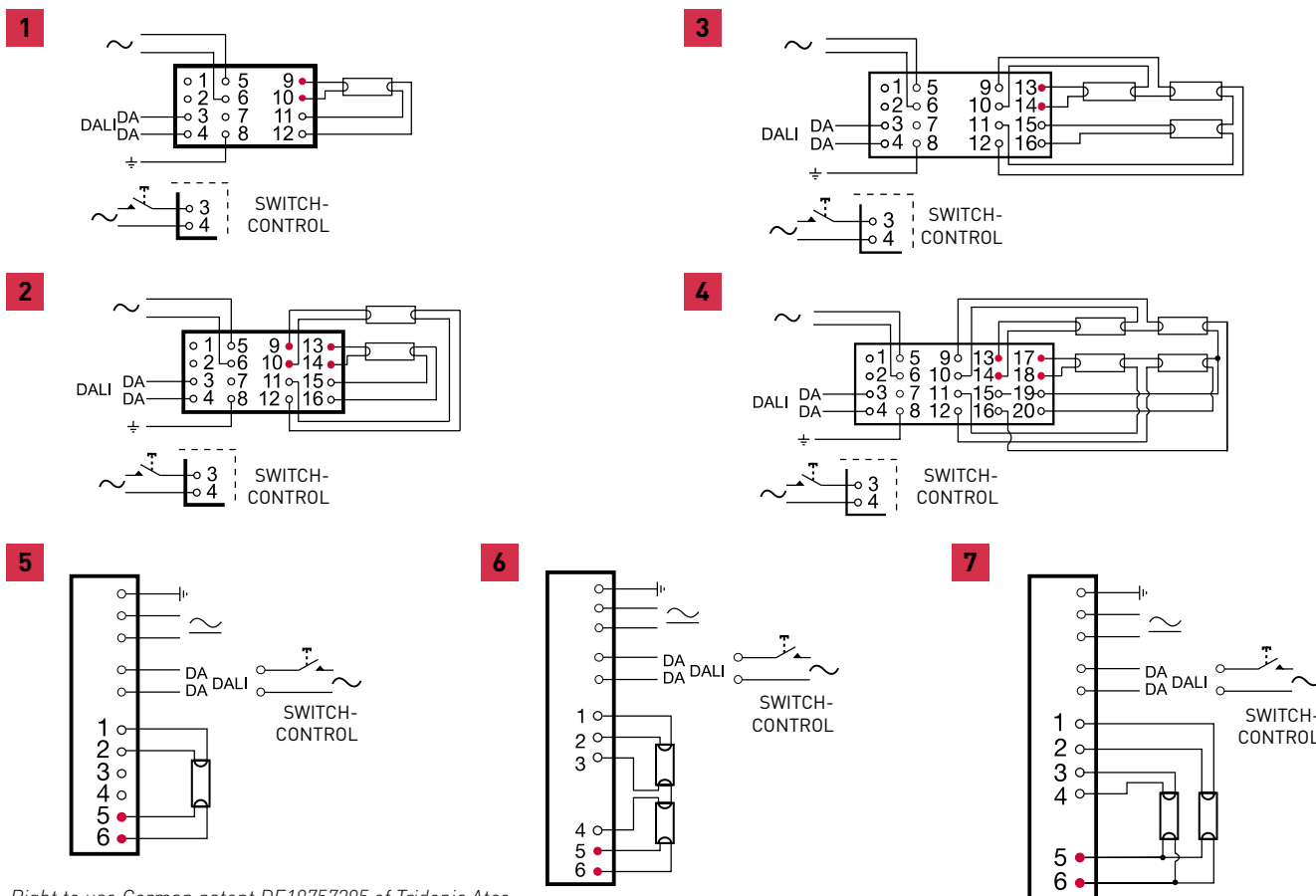

Right to use German patent DE19757295 of Tridonic Atco

1	EL1x ...iDim
2	EL2x ...iDim
3	EL3x ...iDim
4	EL4x ...iDim
5	EL1/2x...iDim-c
6	EL1/2x...iDim-c
7	EL2x...iDim-c

EL-sc

NOTE: All wiring to the connectors marked with a red dot (hot wires) should be as short as possible.

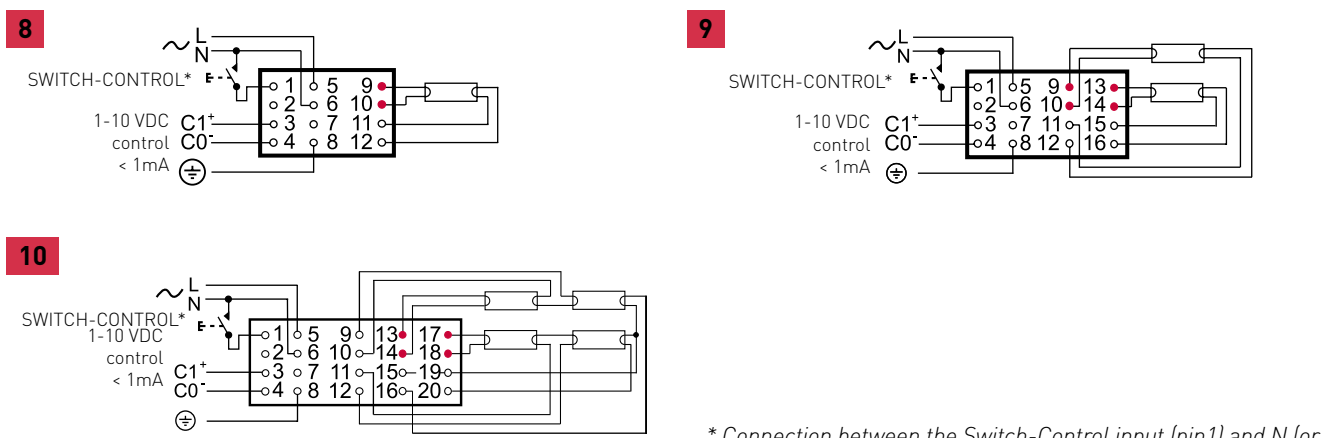

* Connection between the Switch-Control input (pin 1) and N (or L).

1	EL1x ...sc
2	EL2x ...sc
3	EL4x ...sc

	EL-iDim	EL-iDim-c	EL-sc
Max.temperature at t_c point	75 °C ³⁾	75 °C	80 °C
Ambient temperature range	+10...+50 °C ¹⁾⁵⁾⁶⁾	+10...+50 °C ⁵⁾	+10...+50 °C ¹⁾
Storage temperature range	-40...+80 °C	-40...+80 °C	-40...+80 °C
Maximum relative humidity	no condensation	no condensation	no condensation
Number of starts per lamp	> 50 000	> 50 000	> 50 000
AC Range	198-264 VAC	198-264 VAC	198-264 VAC
DC range (starting voltage >198VDC)	176-280 VDC	176-280 VDC	176-280 VDC
Over voltage duration	320 VAC, 1h	320 VAC, 1h	320 VAC, 1 h
EBLF (Emergency Ballast Lumen Factor)	N/A	> 0.5 ⁷⁾	N/A
BLF (Ballast Lumen Factor), steady state	~1	~1	~1
Programmable light output for DC operation	yes	yes	N/A
Power factor (at maximum), typical	0.96	0.96	0.98
Earth leakage current	< 0.4 mA	< 0.4 mA	< 0.4 mA
Maximum working voltage (Uout)	400 V	400 V	400 V
Lifetime (90 % survival)	50 000 h, at t_c	50 000 h, at t_c	50 000 h, at 70 °C t_c
Max length of ballast to lamp wiring	1.5 m / 2 m (hot / cold) ²⁾⁴⁾	1 m / 1 m (hot / cold) ⁴⁾	1.5 m/2 m (hot/cold) ²⁾
Max length of DALI control wires	300 m ⁹⁾	300 m ⁹⁾	N/A
Ignition time, typical	1.0 s	1.0 s ⁸⁾	<1.3 s
Type of starting	Preheat (warm start)	Preheat (warm start)	Preheat (warm start)

1) To ensure stable operation of TC-L lamps in ambient temperatures below 18 °C it is not recommended to dim the light level below 3 %

2) For TC-L lamps 1 m / 2 m (hot/cold lamp wires)

3) For EL 3x14iDim, $t_c = 65$ °C

4) Minimise lamp wire length variations in order to avoid imbalance in light output.

5) When using EL3x14iDim, EL4x14iDim and EL1/2x18/24iDim-c ballasts in ambient temperatures below 15 °C it is not recommended to dim the light level below 10 % to ensure stable lamp operation.

6) For EL2x80iDim, it is not recommended to dim the light below 5 % in temperatures below 15 °C

7) EL2x26-42iDim-c; EBLF > 0,3

8) EL1/2x18/24iDim-c ignition time = 1.4 s

9) Maximum allowed voltage drop is 2 V in 250 m wire

Standards

	EL-iDim	EL-iDim-c	EL-sc
General and safety requirements EN61347-2-3	●	●	●
Additional safety requirements for AC/DC supplied ballasts acc. to EN61347-2-3 Annex J	●	●	N/A
Performance requirements EN60929	●	●	●
Preheat starting	●	●	●
Lamp life acc. to EN60081 / EN60901 ^{*)}	●	●	●
Mains current harmonics, acc. to EN61000-3-2	●	●	●
Radio Frequency Interference, acc. to EN55015	●	●	●
Immunity standard, acc.to EN61547	●	●	●
Vibration test EN60068-2-64 test Fh	●	●	●
Bump test EN60068-2-29 test Eb	●	●	●
Thermal protection class EN61347, C5e	●	●	●
Tested and proven compatible with DALI V1 (IEC62386, 2009)	●	●	N/A

* EN 60081 for T5 & T8 fluorescent lamps, EN 60901 for compact fluorescent lamps

Switch-Control provides ON/OFF switching and UP/DOWN dimming functionality from one or more simple switches.
Switch-Control and DALI can not be connected to the iDim ballast at the same time.

Suitable switch:

- Automatic return type
- Mains rated

Connection:

- EL-iDim ballasts: To the DALI input
- Wire length: 25 m maximum, diagram A
25 - 200 m, use a capacitor (1 μ F, 275 V), diagram B
- Ballasts per switch: 50 (observe above)
- Ensure all ballasts and associated switches are connected to the same mains phase

Operation:

- **Switch off:** Short push of the switch (< 0.4 second)
- **Switch on:** Short push of the switch (< 0.4 second)
- EL-iDim ballasts will switch on to the last set level
- **Dimming:** Long push of the switch (> 0.5 second)
 - If lamps are off, the ballast dims up from minimum
 - If lamps are on, the ballast dims in the opposite direction to previously
 - The first dimming direction is dimming down

Correction of out of sequence operation:

- Switch the mains supply off and on, or...
- Long push (until all lamps are on), then a short push (all lamps off), then switch on

Compatibility:

Some ballasts manufacturers have functionality similar to Helvar Switch-Control. These methods are NOT COMPATIBLE with each other.

Power On to last level function from Switch-Control

Power On to last level function recalls the light level after mains break.
Power On to last level operation sequence:

Activation

- Activation is started with the light switched ON using the following sequence.
 - 1 x long switch (20 - 25 s)
 - 3 x short switch (90 - 360 ms)
 - 1 x long switch (20 - 25 s)
 Between the switches, approximately 2 seconds of delay is allowed.

Deactivation

- Deactivation is started with the light switched OFF (standby) using the following sequence.
 - 1 x long switch (20 - 25 s)
 - 3 x short switch (90 - 360 ms)
 - 1 x long switch (20 - 25 s)
 Between the switches, approximately 2 seconds of delay is allowed.

Connection

- To the DALI input

A) 0-25 m

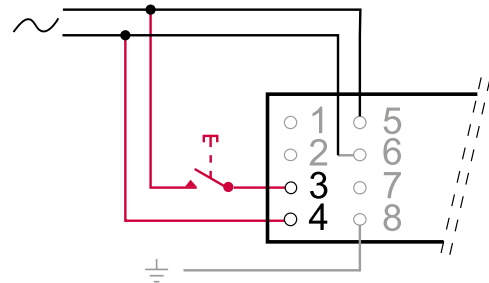

B) 25-200 m

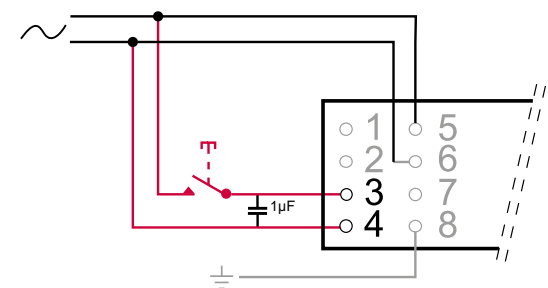

Switch-Control provides ON/OFF switching and UP/DOWN dimming functionality from one or more simple switches. Switch-Control can be used together and simultaneously with other compatible control devices.

- EL-sc ballasts and analogue 1-10 V control.

Suitable switch:

- Automatic return type. Mains rated (Mains is still present at the ballast terminals if the lamps are switched off from Switch-Control).
- The switch should withstand a short circuit current of:
 - 0.2 mA per ballast

Connection:

- Between the Switch-Control input and N (or L).
- Wire length: 200 m maximum.
- Ballasts per switch: 50 (observe above).
- Ensure all ballasts and associated switches are connected to the same mains phase.

Operation:

- **Switch off:** Short push of the switch (<0.4 second).
- **Switch on:** Short push of the switch (<0.4 second).
 - Re-strike within 3 seconds of switch off is prevented to ensure optimal lamp warm start.
 - EL-sc ballasts will switch on to the analogue control set level, both when switching ON from the switch or from the mains supply.
- **Dimming:** Long push of the switch (>0.5 second).
 - If lamps are off, the ballast dims up from minimum.
 - If lamps are on, the ballast dims in the opposite direction to previously.
 - The first dimming direction is dimming up.

Regaining analogue control when Switch-Control is active:

- Dim the analogue control device from min. to max. and back to minimum within 1 second.

Correction of out of sequence operation:

- Switch the mains supply off and on, or...
- Long push (until all lamps are on), then a short push (all lamps off), then wait 3 seconds and switch on (short push).

Compatibility:

Some ballasts manufacturers have functionality similar to Helvar Switch-Control. In most cases these methods are NOT COMPATIBLE with each other.

Connection

Between the Switch-Control input (pin1) and L (or N).

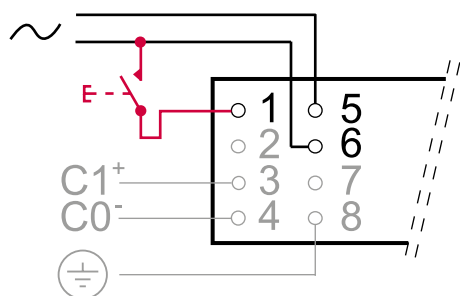

Standard electronic ballasts – highest energy savings and reliability

Continuous research and development in new technologies has led to the introduction of a host of innovative products over the years. Among the latest of these are the EL-ngn5 standard electronic ballasts with the nominal lifetime up to 100 000 hours at Ta 50 with 90 % survival.

These ballasts are characterized by excellent thermal design, resulting in the highest energy savings and highest reliability, and embodying Helvar's 'green values' that help to guarantee minimum environmental impact!

Helvar uses only the highest-quality components and materials in the manufacture of its ballasts, and combines this with quality design and extensive testing under the harshest conditions. It's hardly surprising then that failure rates are among the lowest in the market, exceeding industrial expectations 10-fold!

Helvar's manufacturing processes are also certified to ISO 9001 and ISO14001.

EL-ngn5 – SETTING NEW STANDARDS

Helvar has once again set a new standard for T5 high performance electronic ballasts with EL-ngn5 range. Its single lamp versions up to 54 W has a length of only 190 mm with a height of 21 mm. This offers a great possibilities for luminaire designers in designing sleek T5 luminaires without compromises.

Excellent EMC performance make them suitable for use in protection class II fittings. Moreover, its multi-lamp operation feature enables one ballast to drive all HE-T5 lamps in an installation. It is also possible to drive a combination of T5/TC-L lamps with one ballast. This offers major advantages in reduced logistics and transportation costs, as well as contributing to reduced CO₂ emissions.



EL-ngn – THE NEXT GENERATION

The EL-ngn is a high specification electronic ballast range for high-volume T8 markets from Helvar. Its no-compromise design offers the highest specifications, and its green credentials are confirmed by the fact that it has the highest Energy Efficiency Index. It is also considered to be one of the most user-friendly ballasts, and its proven reliability means that it is widely accepted by even the most demanding and quality-conscious OEMs.

The EL-ngn is available for T8 lamps in 1-, 2- and 4-lamp configurations.

EL-TCs – THE COOL RUNNER

EL-TCs range is capable of driving as many as 50 lamps in various TC-DE, TC-TE, TC-SE, TC-DD, T5c, TC-L, TC-F, PL-R, T8 and T5 lamp combinations! The beauty of the ballasts is their 'dual-technology' that cost-effectively combines both single- and twin- lamp versions into one ballast.

What's more, the EL-TCs is surprisingly small, yet it is still capable of running cool even under full thermal stress, thanks to its OCC technology and the clever thermal design of its PCB. This feature has been praised by many OEMs and it is widely acknowledged to be the most reliable CFL ballast in the market.

EL-es – THE ECO SAVER

The EL-es is a electronic ballast range for high-volume T8 markets from Helvar. It is developed to meet the needs of luminaire designers looking to replace magnetic ballasts with an electronic version combining the benefits of both!

The EL-es is available for T8 lamps in 2- and 4-lamp configurations.



Electronic ballasts for T5 fluorescent lamps

14-80 W 220-240 V, 50-60 Hz

- Smallest available quality ballast
- Standard & sidemount possibilities
- Optimal lamp operation
- Low power losses
- Long lifetime
- Green values
- High power factor



A2 BAT



Lamp type	Wattage	No. of lamps	Ballast	EEI	Dimensions	Connection	Weight	Circuit power	Mains current	Lamp power
						(p.30)				
T5	14	1	EL1x14-35ngn5	A2 BAT	1	1	127	15.5	0.08-0.06	13.7
	14	2	EL2x14-35ngn5	A2 BAT	2	12	204	31	0.16-0.15	13.7
	14	3	EL3/4x14ngn5	A2	2	6	204	46	0.22-0.19	13.7
	14	4	EL3/4x14ngn5	A2	2	7	204	62	0.29-0.26	13.7
	14	4	EL4x14ngn5	A2 BAT	2	7	190	63	0.30-0.26	13.7
	21	1	EL1x14-35ngn5	A2 BAT	1	1	127	23	0.12-0.10	20.7
	21	2	EL2x14-35ngn5	A2 BAT	2	12	204	45	0.22-0.19	20.7
	24	1	EL1x24ngn5	A2	1	1	130	25	0.12-0.11	22.5
	24	2	EL2x24ngn5	A2 BAT	2	8	193	49	0.24-0.21	22.5
	24	3	EL3/4x24ngn5	A2 BAT	2	6	208	73	0.34-0.30	22.5
	24	4	EL3/4x24ngn5	A2 BAT	2	7	208	97	0.44-0.40	22.5
	28	1	EL1x14-35ngn5	A2 BAT	1	1	127	30	0.15-0.12	27.8
	28	2	EL2x14-35ngn5	A2 BAT	2	12	204	60	0.29-0.25	27.8
	35	1	EL1x14-35ngn5	A2 BAT	1	1	127	38	0.18-0.16	34.7
	35	2	EL2x14-35ngn5	A2 BAT	2	12	204	75	0.35-0.31	34.7
	39	1	EL1x39/36ngn5	A2 BAT	1	1	130	42	0.19-0.18	38
	39	2	EL2x39/36ngn5	A2 BAT	2	8	195	81	0.36-0.32	38
	49	1	EL1x49ngn5	A2 BAT	1	1	130	55	0.25-0.23	49.3
	49	2	EL2x49ngn5	A2 BAT	2	12	211	105	0.50-0.45	49.3
	49	2	EL2x49ngn5-XL	A2 BAT	3	12	265	105	0.50-0.45	49.3
	54	1	EL1x54ngn5	A2 BAT	1	1	130	58	0.26-0.24	53.8
	54	2	EL2x54ngn5	A2 BAT	2	8	206	115	0.53-0.48	53.8
	54	2	EL2x54ngn5-XL	A2 BAT	3	8	260	115	0.53-0.48	53.8
	80	1	EL1x80ngn5	A2 BAT	2	1	192	86	0.42-0.36	80
	80	2	EL2x80ngn5	A2 BAT	3	12	300	170	0.80-0.73	80

Note: See pages 30-33 for connection diagrams and additional characteristics.

Dimensions	1	2	3
Lenght 'a' (mm)	190	280	360
Width 'b' (mm)	30	30	30
Height 'c' (mm)	21	21	21
'd' (mm)	180	270	350

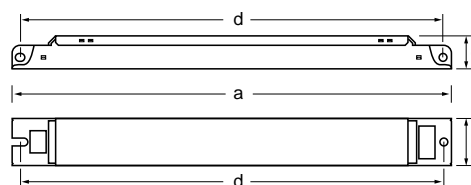

Delivery information

Ballast	Unit package		Transportation package		
	Minimum delivery amount	Plastic binding strip	One-way pallet 1200 x 820 (pcs.)	Pallet weight (kg)	Pallet height (cm)
EL1 x ngn5	10	●	2000	260-300	48
EL2 x ngn5 & EL3/4 x ngn5	10	●	2000	400-450	56
EL2x55ngn5 & EL2x80ngn5	10	●	1500	400-420	56

Electronic ballasts for T5-eco fluorescent lamps

14-80 W 220-240 V, 50-60 Hz

- Smallest available quality ballast
- Standard & sidemount possibilities
- Optimal lamp operation
- Low power losses
- Long lifetime
- Green values
- High power factor



A2 BAT

Lamp type	No. of lamps	Ballast	EEI	Dimensions	Connection	Weight	Circuit power ¹⁾	Mains current ¹⁾	Lamp power ¹⁾
							(W)	(A)	(W)
T5 eco	14 eco	1	EL1x14-35ngn5	A2 BAT	1	127	15.5	0.08-0.06	13.7
	14 eco	2	EL2x14-35ngn5	A2 BAT	2	204	31	0.16-0.15	13.7
	14 eco	3	EL3/4x14ngn5	A2	2	204	46	0.22-0.19	13.7
	14 eco	4	EL3/4x14ngn5	A2	2	204	62	0.29-0.26	13.7
	14 eco	4	EL4x14ngn5	A2 BAT	2	190	63	0.30-0.26	13.7
	21 eco	1	EL1x14-35ngn5	A2 BAT	1	127	23	0.12-0.10	20.7
	21 eco	2	EL2x14-35ngn5	A2 BAT	2	204	45	0.22-0.19	20.7
	24 eco	1	EL1x24ngn5	A2	1	130	25	0.12-0.11	22.5
	24 eco	2	EL2x24ngn5	A2 BAT	2	193	49	0.24-0.21	22.5
	24 eco	3	EL3/4x24ngn5	A2 BAT	2	208	73	0.34-0.30	22.5
	24 eco	4	EL3/4x24ngn5	A2 BAT	2	208	97	0.44-0.40	22.5
	28 eco	1	EL1x14-35ngn5	A2 BAT	1	127	30	0.15-0.12	27.8
	28 eco	2	EL2x14-35ngn5	A2 BAT	2	204	60	0.29-0.25	27.8
	35 eco	1	EL1x14-35ngn5	A2 BAT	1	127	38	0.18-0.16	34.7
	35 eco	2	EL2x14-35ngn5	A2 BAT	2	204	75	0.35-0.31	34.7
	39 eco	1	EL1x39/36ngn5	A2 BAT	1	130	42	0.19-0.18	38
	39 eco	2	EL2x39/36ngn5	A2 BAT	2	195	81	0.36-0.32	38
	49 eco	1	EL1x49ngn5	A2 BAT	1	130	55	0.25-0.23	49.3
	49 eco	2	EL2x49ngn5	A2 BAT	2	211	105	0.50-0.45	49.3
	49 eco	2	EL2x49ngn5-XL	A2 BAT	3	265	105	0.50-0.45	49.3
	54 eco	1	EL1x54ngn5	A2 BAT	1	130	58	0.26-0.24	53.8
	54 eco	2	EL2x54ngn5	A2 BAT	2	206	115	0.53-0.48	53.8
	54 eco	2	EL2x54ngn5-XL	A2 BAT	3	260	115	0.53-0.48	53.8
	80 eco	1	EL1x80ngn5	A2 BAT	2	192	86	0.42-0.36	80
	80 eco	2	EL2x80ngn5	A2 BAT	3	300	170	0.80-0.73	80

Note: See pages 30-33 for connection diagrams and additional characteristics.

1) Maximum 10 % energy saving achieved from declared maximum value depending on difference in lamps from various manufacturers.

Dimensions	1	2	3
Lenght 'a' (mm)	190	280	360
Width 'b' (mm)	30	30	30
Height 'c' (mm)	21	21	21
'd' (mm)	180	270	350

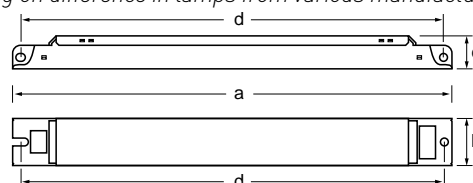

Delivery information

Ballast	Unit package		Transportation package		
	Minimum delivery amount	Plastic binding strip	One-way pallet 1200 x 820 (pcs.)	Pallet weight (kg)	Pallet height (cm)
EL1 x ngn5	10	●	2000	260-300	48
EL2 x ngn5 & EL3/4 x ngn5	10	●	2000	400-450	56
EL2x55ngn5 & EL2x80ngn5	10	●	1500	400-420	56

Electronic ballasts for T8 fluorescent lamps

14-58 W 220-240 V, 50-60 Hz

- Energy saving
- Warm Start according to lamp standards
- Flickerless light
- Covers EMC requirements
- Low harmonics
- Low power losses
- Stabilized output



A2 BAT

Lamp type	Wattage	No. of lamps	Ballast	EEI	Dimensions	Connection	Weight	Circuit power	Mains current	Lamp power
						(p.30)	(g)	(W)	(A)	(W)
T8	14	1	EL1x15ngn ¹⁾	A2	3	1	120	15	0.09-0.07	13
	15	1	EL1x15ngn ¹⁾	A2	3	1	120	15,5	0.09-0.07	13.5
	18	1	EL1x18ngn	A2	1	1	190	19	0.09-0.08	16
	18	2	EL2x18ngn	A2 BAT	1	8	200	37	0.16-0.15	16
	18	3	EL3/4x18ngn	A2	2	6	210	52	0.25-0.23	16
	18	4	EL3/4x18ngn	A2	2	7	210	69	0.33-0.30	16
	18	4	EL4x18ngn	A2 BAT	1	9	200	72	0.33-0.30	16
	30	1	EL1x30ngn ¹⁾	A2 BAT	3	1	120	26,5	0.14-0.11	24
	36	1	EL1x36ngn	A2	1	1	191	36	0.16-0.15	32
	36	2	EL2x36ngn	A2 BAT	1	8	205	71	0.32-0.29	32
	58	1	EL1x58ngn	A2	1	1	193	55	0.26-0.23	50
	58	2	EL2x58ngn	A2 BAT	1	8	218	108	0.50-0.45	50

Note: See pages 31-32 for connection diagrams and additional characteristics.

1) ENEC and EMC approvals by request.

Dimensions	1	2	3
drawing	a	b	c
Length 'a' (mm)	280	280	190
Width 'b' (mm)	30	30	30
Height 'c' (mm)	28	21	21
'd' (mm)	270	270	180

Delivery information					
Ballast	Unit package		Transportation package		
	Minimum delivery amount	Plastic binding strip	One-way pallet 1200 x 820 (pcs.)	Pallet weight (kg)	Pallet height (cm)
EL1 x ngn	10	●	1600	330	60
EL2 x ngn	10	●	1600	320-360	60
EL3/4x18ngn	10	●	1500	385	57
EL4 x ngn	10	●	1600	370	60

Note: Delivery information for EL1x15ngn and EL1x30ngn as on a page 21 for EL1 x ngn5

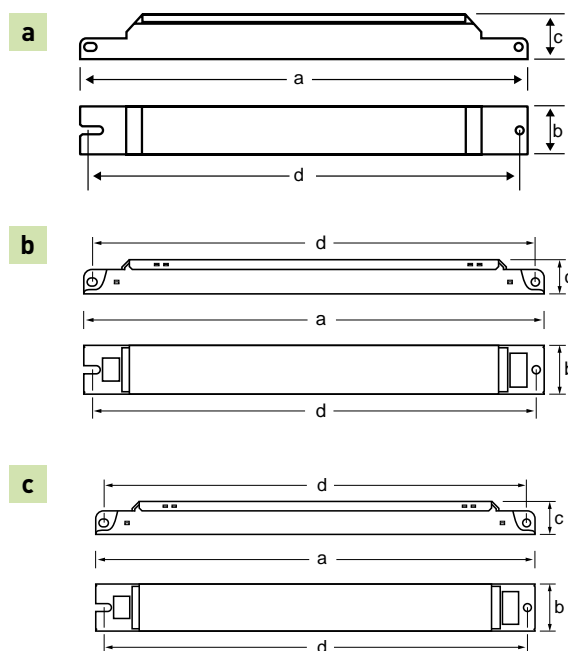

Electronic ballasts for T8 fluorescent lamps

18-70 W 220-240 V, 50-60 Hz

- Only 21 mm high
- Optimal lamp operation
- Wide operational ambient temperature range
- Standard & sidemount possibilities
- Optional terminals for automatic wiring
- Low power losses
- Silent operation
- Stabilized flickerfree light
- High power factor



A2

Lamp type	Wattage	No. of lamps	Ballast	EEL	Dimensions	Connection	Weight	Circuit power	Mains current	Lamp power
						(p.30)	(g)	(W)	(A)	(W)
T8	58	2	EL2x58s	A2	2	2	260	106.5	0.50-0.45	50
	70	1	EL1x70s	A2	13	13	200	64.5	0.30-0.28	60
	70	2	EL2x70s	A2	2	2	260	128	0.59-0.54	60

Note: See pages 31-32 for connection diagrams and additional characteristics.

Dimensions	1	2
drawing	a	a
Length 'a' (mm)	280	360
Width 'b' (mm)	30	30
Height 'c' (mm)	21	21
'd' (mm)	270	350

Delivery information					
Ballast	Unit package		Transportation package		
	Minimum delivery amount	Plastic binding strip	One-way pallet 1200 x 820 (pcs.)	Pallet weight (kg)	Pallet height (cm)
EL1 x s	10	●	2000	350 - 420	57
EL2 x s	10	●	1500	395	57

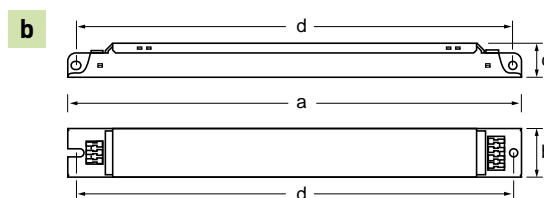
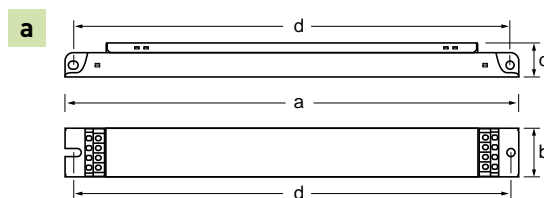

Electronic ballasts for T8 fluorescent lamps

- Energy saver
- Stabilized flickerfree light
- Approved warm start
- High power factor
- Silent operation
- Good EMC performance

18-58 W 220-240 V, 50-60 Hz



A2

Lamp type	Wattage	No. of lamps	Ballast	EEL	Connection (p.30)	Weight (g)	Circuit power (W)	Mains current (A)	Lamp power (W)
T8	18	4	EL4x18es	A2	9	190	72	0.30-0.33	16
	36	2	EL2x36es	A2	8	190	71	0.32-0.29	32
	58	2	EL2x58es	A2	8	200	108	0.50-0.45	50

Note: See pages 31-32 for connection diagrams and additional characteristics.

Dimensions	1
drawing	a
Length 'a' (mm)	280
Width 'b' (mm)	30
Height 'c' (mm)	28
'd' (mm)	270

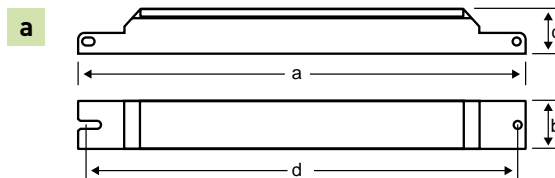

Delivery information

Ballast	Unit package		Transportation package		
	Minimum delivery amount	Plastic binding strip	One-way pallet 1200 x 820 (pcs.)	Pallet weight (kg)	Pallet height (cm)
EL4x18es	10	●	1600	330	60
EL2x36es	10	●	1600	330	60
EL2x58es	10	●	1600	350	60

Electronic ballasts for T8 fluorescent lamps

18-58 W 220-240 V, 50-60 Hz

- Efficient and easy lamp replacement
- Compact size
- Light weight
- RoHS compliant



A2

Lamp type	Wattage	No. of lamps	Ballast	EEI	Dimensions	Connection	Weight	Circuit power	Mains current	Lamp power
						(p.30)	(g)	(W)	(A)	(W)
T8	18	1	EL1x18ef	A2	1	3	87	18	0.08-0.09	15
	18	2	EL2x18ef	A2	1	4	91	37	0.15-0.17	16
	18	4	EL4x18ef	A2	2	5	135	70	0.32-0.34	16
	36	1	EL1x36ef	A2	1	3	87	35	0.15-0.17	32
	36	2	EL2x36ef	A2	2	4	128	70	0.32-0.34	32
	58	1	EL1x58ef	A2	1	3	104	53	0.23-0.25	50

Note: See pages 31-32 for connection diagrams and additional characteristics.

Dimensions	1	2
Length 'a' (mm)	150	210
Width 'b' (mm)	40	40
Height 'c' (mm)	28	30
'd' (mm)	140	200

Delivery information				
Type	Minimum delivery amount	EUR pallet 1200 x 800 (pcs.)	Pallet weight (kg)	Pallet height (cm)
EL1x18ef	50	2750	260	98
EL2x18ef	50	2750	270	98
EL1x36ef	50	2750	260	98
EL2x36ef	50	1400	200	86
EL1x58ef	50	2750	300	98
EL4x18ef	50	1400	210	86

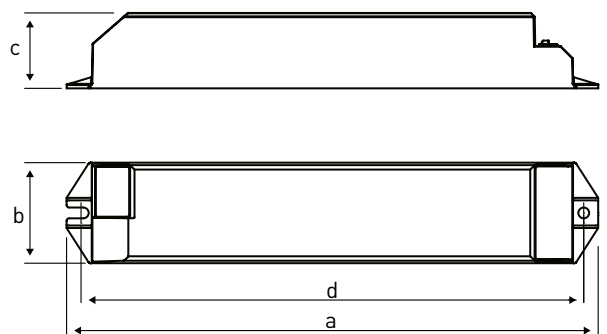

Electronic ballasts for compact fluorescent lamps

14-80 W 220-240 V, 50-60 Hz

- Smallest available quality ballast
- Standard & sidemount possibilities
- Optimal lamp operation
- Low power losses
- Long lifetime
- Green values
- High power factor



A2 BAT

Lamp type	Wattage	No. of lamps	Ballast	EEI	Dimensions	Connection	Weight	Circuit power	Mains current	Lamp power
						(p.30)	(g)	(W)	(A)	(W)
TC-L	24	1	EL1x24ngn5	A2	1	1	130	25	0.12-0.11	22.5
	24	2	EL2x24ngn5	A2 BAT	2	8	193	49	0.24-0.21	22.5
	24	3	EL3/4x24ngn5	A2 BAT	2	6	208	73	0.34-0.30	22.5
	24	4	EL3/4x24ngn5	A2 BAT	2	7	208	97	0.44-0.40	22.5
	36	1	EL1x39/36ngn5	A2	1	1	130	35	0.16-0.15	32
	36	2	EL2x39/36ngn5	A2 BAT	2	8	195	69	0.32-0.29	32
	55	1	EL1x55ngn5 ¹⁾	A2 BAT	2	1	195	60	0.28-0.24	55
	55	2	EL2x55ngn5	A2 BAT	3	8	240	118	0.54-0.49	55
	80	1	EL1x80ngn5	A2 BAT	2	1	192	86	0.42-0.36	80
	80	2	EL2x80ngn5	A2 BAT	3	13	300	170	0.80-0.73	80

Note: See pages 30-33 for connection diagrams and additional characteristics.

1) Also ENEC approved for 55 W T5-C lamps

Dimensions	1	2	3
Lenght 'a' (mm)	190	280	360
Width 'b' (mm)	30	30	30
Height 'c' (mm)	21	21	21
'd' (mm)	180	270	350

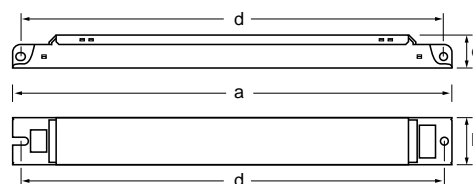

Ballast	Unit package		Transportation package		
	Minimum delivery amount	Plastic binding strip	One-way pallet 1200 x 820 (pcs.)	Pallet weight (kg)	Pallet height (cm)
EL1 x ngn5	10	●	2000	260-300	48
EL2 x ngn5 & EL3/4 x ngn5	10	●	2000	400-450	56
EL2x55ngn5 & EL2x80ngn5	10	●	1500	400-420	56

Electronic ballasts for compact fluorescent lamps

freedom in lighting

- Slim, only 28 mm high
- Multilamp operation
- Single and twin lamp operation
- Low power losses
- Single case size

18-40 W 220-240 V, 50-60 Hz



A2 BAT

Lamp type	Wattage	No. of lamps	Ballast	EEL	Connection (p.30)	Weight (g)	Circuit power (W)	Mains current (A)	Power factor	Lamp power (W)
TC-L	18	1	EL1/2x18-42TCs	A2 BAT	11	132	17	0.08	0.94c	14.8
	18	2	EL1/2x18-42TCs	A2 BAT	12	132	32	0.14	0.97	14.8
	24	1	EL1/2x18-42TCs	A2 BAT	11	132	26	0.12	0.95	23
	24	2	EL1/2x18-42TCs	A2 BAT	12	132	48	0.21	0.98	22.3
	36	1	EL1/2x36/38TCs	A2 BAT	11	132	37	0.17	0.96	34
	36	1	EL1/2x18-42TCs ¹⁾²⁾	A2 BAT	12	132	31	0.14	0.96	28
	36	2	EL1/2x36/38TCs	A2 BAT	12	132	72	0.32	0.97	33
	40	1	EL1/2x18-42TCs ¹⁾	A2 BAT	11	132	42	0.19	0.98	39
TC-F	18	1	EL1/2x18-42TCs	A2 BAT	11	132	17	0.08	0.94c	14.8
	18	2	EL1/2x18-42TCs	A2 BAT	12	132	32	0.14	0.97	14.8
	24	1	EL1/2x18-42TCs	A2 BAT	11	132	26	0.12	0.95	23
	24	2	EL1/2x18-42TCs	A2 BAT	12	132	48	0.21	0.98	22.3
	36	1	EL1/2x36/38TCs	A2 BAT	11	132	37	0.17	0.96	34
	36	1	EL1/2x18-42TCs ¹⁾²⁾	A2 BAT	12	132	31	0.14	0.96	28
	36	2	EL1/2x36/38TCs	A2 BAT	12	132	72	0.32	0.97	33

Note: See pages 30-33 for connection diagrams and additional characteristics.

1) Tested and recommended by Helvar, not ENEC approved

2) Light output 93 %

Dimensions

Length 'a' (mm)	103.5
Width 'b' (mm)	67
Height 'c' (mm)	28
'd' (mm)	83.5
'e' (mm)	57.5
'f' (mm)	93.5
'g' (mm)	25.5

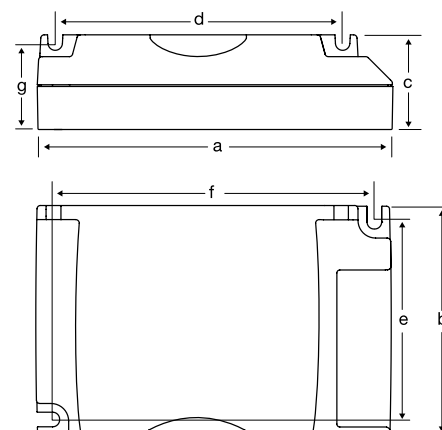

Delivery information

Ballast	Unit package		Transportation package		
	Minimum delivery amount	Carton Box	Pallet 820x1280 (pcs.)	Pallet weight (kg)	Pallet height (cm)
EL-TCs	60	●	1800	260	105

Electronic ballasts for compact fluorescent lamps

9-40 W 220-240 V, 50-60 Hz

- Slim, only 28 mm high
- Multilamp operation
- Single and twin lamp operation
- Low power losses
- Single case size



A2 BAT

Lamp type	Wattage	No. of lamps	Ballast	EEL	Connection (p.30)	Weight (g)	Circuit power (W)	Mains current (A)	Power factor	Lamp power (W)
TC-DD	10	1	EL1/2x9-13TCs	A2 BAT	11	118	12	0.05	0.91c	10.0
	16	1	EL1/2x9-13TCs	A2 BAT	11	118	17	0.08	0.95	15
	21	1	EL1/2x18-42TCs ¹⁾	A2 BAT	11	132	25	0.11	0.97	22.3
	28	1	EL1/2x18-42TCs	A2 BAT	11	132	29	0.13	0.97	27.0
	38	1	EL1/2x36/38TCs	A2 BAT	11	132	38	0.17	0.96	34.8
	38	2	EL1/2x36/38TCs	A2 BAT	12	132	74	0.32	0.97	34
T5c	22	1	EL1/2x18-42TCs	A2 BAT	11	132	25	0.12	0.95	22.6
	40	1	EL1/2x18-42TCs	A2 BAT	11	132	41	0.19	0.98	38.6
T5	14	1	EL1/2x9-13TCs ¹⁾	A2 BAT	11	118	16	0.07	0.95	14.7
	21	1	EL1/2x9-13TCs ¹⁾	A2 BAT	11	118	22.5	0.10	0.97	21
	28	1	EL1/2x9-13TCs ¹⁾	A2 BAT	11	118	31	0.14	0.97	28.2
T8	30	2	EL2x32/42TCs ¹⁾	A2 BAT	11	132	57.5	0.25	0.97	26.6
TC-SE	9	1	EL1/2x9-13TCs	A2 BAT	11	118	10	0.05	0.9c	8.5
	9	2	EL1/2x9-13TCs	A2 BAT	12	118	18	0.08	0.96	8.5
	11	1	EL1/2x9-13TCs	A2 BAT	11	118	14	0.07	0.93c	12.8
	11	2	EL1/2x9-13TCs	A2 BAT	12	118	27	0.12	0.98	12.9
PL-R	14	1	EL1/2x14/17TCs ¹⁾	A2 BAT	11	131	18	0.08	0.92c	15.8
	14	2	EL1/2x14/17TCs ¹⁾	A2 BAT	12	131	34	0.15	0.96	15.5
	17	1	EL1/2x14/17TCs ¹⁾	A2 BAT	11	131	21.5	0.1	0.93c	19.3
	17	2	EL1/2x14/17TCs	A2 BAT	12	131	41	0.18	0.96	18.6

Note: See pages 30-33 for connection diagrams and additional characteristics.

1) Tested and recommended by Helvar, not ENEC approved

Dimensions

Length 'a' (mm)	103.5
Width 'b' (mm)	67
Height 'c' (mm)	28
'd' (mm)	83.5
'e' (mm)	57.5
'f' (mm)	93.5
'g' (mm)	25.5

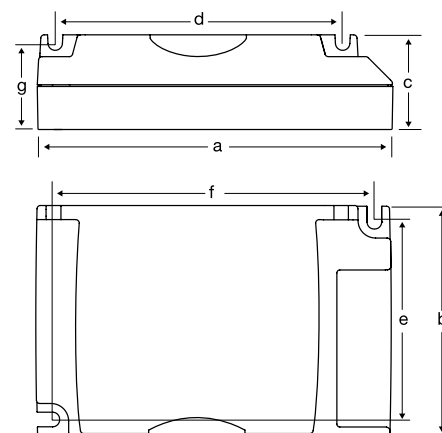

Delivery information

Ballast	Unit package		Transportation package		
	Minimum delivery amount	Carton Box	Pallet 820x1280 (pcs.)	Pallet weight (kg)	Pallet height (cm)
EL-TCs	60	●	1800	260	105

Electronic ballasts for compact fluorescent lamps

freedom in lighting

- Slim only 28 mm high
- Multilamp operation
- Single and twin lamp operation
- Low power losses
- Single case size

9-26 W 220-240 V, 50-60 Hz



A2 BAT

Lamp type	Wattage	No. of lamps	Ballast	EEL	Connection (p.30)	Weight (g)	Circuit power (W)	Mains current (A)	Power factor	Lamp power (W)
TC-DE	10	1	EL1/2x9-13TCs	A2 BAT	11	118	10	0.05	0.9c	8.9
	10	2	EL1/2x9-13TCs	A2 BAT	12	118	20	0.09	0.97	8.9
	13	1	EL1/2x9-13TCs	A2 BAT	11	118	15	0.07	0.94c	13.8
	13	2	EL1/2x9-13TCs	A2 BAT	12	118	28	0.13	0.98	13.5
	18	1	EL1/2x18TCs	A2 BAT	11	120	19	0.09	0.96	16.9
	18	2	EL1/2x18TCs	A2 BAT	12	120	36	0.16	0.98	16.9
	26	1	EL1/2x18-42TCs	A2 BAT	11	132	27	0.13	0.96	24.7
	26	2	EL1/2x18-42TCs	A2 BAT	12	132	51	0.23	0.98	23.8
TC-TE	26	2	EL2x32/42TCs	A2 BAT	12	132	53	0.24	0.97	24
	13	1	EL1/2x9-13TCs	A2 BAT	11	118	15	0.07	0.94c	13.8
	13	2	EL1/2x9-13TCs	A2 BAT	12	118	28	0.13	0.98	13.5
	18	1	EL1/2x18TCs	A2 BAT	11	120	19	0.09	0.96	16.9
	18	2	EL1/2x18TCs	A2 BAT	12	120	36	0.16	0.98	16.9
	26	1	EL1/2x18-42TCs	A2 BAT	11	132	27	0.13	0.96	24.7
	26	2	EL1/2x18-42TCs	A2 BAT	12	132	51	0.23	0.98	23.8
	26	2	EL2x32/42TCs	A2 BAT	12	132	53	0.24	0.97	24
	32	1	EL1/2x18-42TCs	A2 BAT	11	132	32	0.15	0.97	29.4
	32	2	EL2x32/42TCs	A2 BAT	12	132	64	0.29	0.98	28.5
	42	1	EL1/2x18-42TCs	A2 BAT	11	132	44	0.2	0.98	42.2
	42	2	EL2x32/42TCs	A2 BAT	12	132	85	0.38	0.98	40.5
57	1	EL1/2x18-42TCs	A2 BAT	11	132	58.5	0.26	0.99	54	

1) Ballast Lumen Factor for 1x14 W, 2x14 W, 1x17 W: 107 %

Note: See pages 30-33 for connection diagrams and additional characteristics.

Dimensions

Length 'a' (mm)	103.5
Width 'b' (mm)	67
Height 'c' (mm)	28
'd' (mm)	83.5
'e' (mm)	57.5
'f' (mm)	93.5
'g' (mm)	25.5

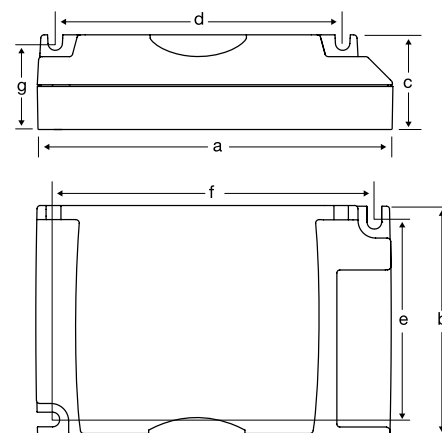

Delivery information

Ballast	Unit package		Transportation package		
	Minimum delivery amount	Carton Box	Pallet 820x1280 (pcs.)	Pallet weight (kg)	Pallet height (cm)
EL-TCs	60	●	1800	260	105

Connection diagrams

EL-ngn5, EL-s, EL-ngn, EL-es, EL-ef, EL-TCs

NOTE: All wiring to the connectors marked with a red dot (hot wires) should be as short as possible.

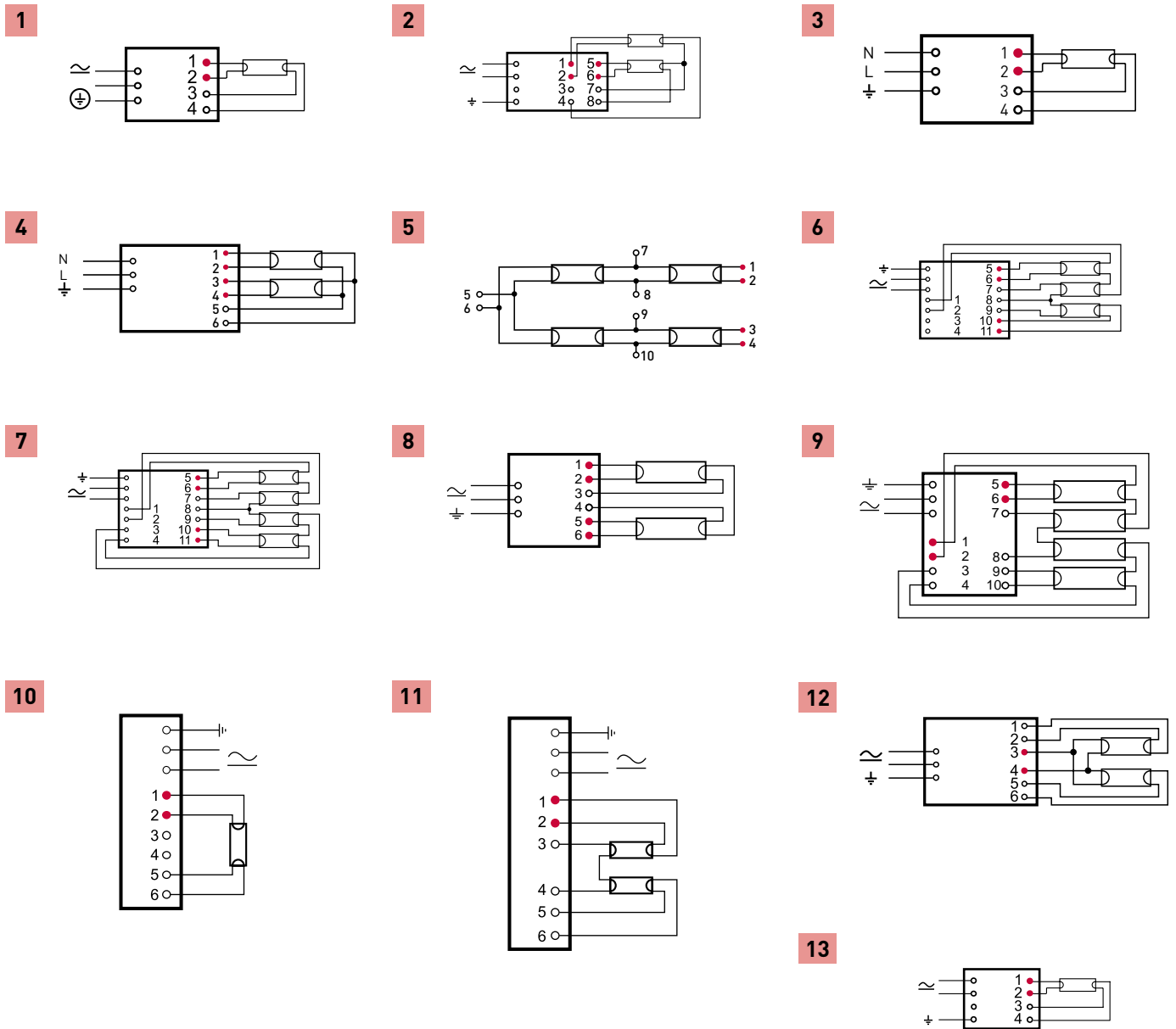

1	EL1x...ngn, EL1x...ngn5
2	EL2x58s, EL2x70s
3	EL1x18ef, EL1x36ef, EL1x58ef
4	EL2x18ef, EL2x36ef
5	EL4x18ef
6	EL3/4x18ngn (three lamp connection), EL3/4x14ngn5, EL3/4x24ngn5
7	EL3/4x18ngn (four lamp connection), EL3/4x14ngn5, EL3/4x24ngn5, EL4x14ngn5
8	EL2x18ngn, EL2x36ngn, EL2x58ngn, EL2x24ngn5, EL2x39/36ngn5, EL2x54ngn5, EL2x54ngn5-XL, EL2x55ngn5, EL2x36es, EL2x58es
9	EL4x18ngn, EL4x18es
10	EL1/2x14/17TCs, EL1/2x18-42TCs, EL1/2x18TCs, EL1/2x9-13TCs, EL1/2x36/38TCs
11	EL1/2x14/17TCs, EL1/2x18-42TCs, EL1/2x18TCs, EL1/2x9-13TCs, EL2x32/42TCs, EL1/2x36/38TCs
12	EL2x14-35ngn5, EL2x49ngn5, EL2x49ngn5-XL, EL2x80ngn5
13	EL1x ...s

	EL-s	EL-ngn	EL-ngn5	EL-es	EL-TCs	EL-ef
Max. temperature at t_c point	75 °C ³⁾	75 °C	75 °C ⁷⁾¹⁰⁾	75 °C	75 °C	70 °C
Ambient temperature range	-20...+50 °C	-20...+50 °C	-20...+50 °C ¹¹⁾	-15...+50 °C	-20...+50 °C	-15...+50 °C
Storage temperature range	-40...+80 °C	-40...+80 °C	-40...+80 °C	-40...+80 °C	-40...+80 °C	-40...+80 °C
Maximum relative humidity	no condensation	no condensation	no condensation	no condensation	no condensation	no condensation
Number of starts per lamp	> 50 000	> 60 000	> 50 000	> 20 000	> 50 000	> 6 000
AC Range	198-264 VAC ⁴⁾⁵⁾	198-264 VAC	198-264 VAC	198-264 VAC	198-264 VAC	220 - 240 VAC
DC range (starting voltage >190VDC)	176-280 VDC ⁵⁾	176-280 VDC	176-280 VDC	198-264 VDC ⁹⁾	176-280 VDC ¹¹⁾	220 - 240 VDC
Over voltage duration	320 VAC, 1 h	320 VAC, 1 h	320 VAC, 1 h	320 VAC, 1 h	320 V / 1 h	270 VAC, 2 h
Power factor (at maximum), typical	0.98	0.98	0.98	0.98	> 0.95	0.95
Earth leakage current	< 0.4 mA	< 0.4 mA	< 0.4 mA	< 0.4 mA	< 0.4 mA	< 0.4 mA
Maximum working voltage (Uout)	400 V	350 V ⁶⁾	400 V ⁶⁾	350 V ⁶⁾	250 V ²⁾	280 V ¹²⁾
Lifetime (90 % survival)	50 000 h, at t_c	60 000 h, at t_c	60 000 h, ⁸⁾ at t_c >100 000h, at T_a 50°C	50 000 h, at t_c	50 000 h, at t_c	30 000 h, at T_c 45 000 h, at T_a 50°C
Max length of ballast to lamp wiring	2 m	1.5 m	2 m	1.5 m	1 m / 2 m (hot / cold)	2 m
Ignition time, typical	~1.0 s	< 1 s	~1 s	< 2 s	~1 s	0.3 s

1) For 2 x 42 W lamp, DC range is 190-280 V

2) EL2x32/42TCs 300 V

3) For EL 2x70s, $t_c = 70$ °C

4) For EL2x70s AC range is 204-264 V

5) EL2x70s max 6 hours at 176-190 VDC

6) 3/4x18ngn, Uout = 400 V

7) 70 °C EL3/4x14ngn5

8) Please see page 33 for detailed information

9) Operationally suitable for emergency use with central battery

10) 85 °C, for EL-ngn5-XL-types

11) max T_a 65 °C, for EL-ngn5-XL-types

12) Uout = 380 V for EL2x36ef & EL4x18ef

Standards

	EL-s / EL-su	EL-ngn	EL-ngn5	EL-es	EL-TCs	EL-ef
General and safety requirements EN61347-2-3	●	●	●	●	●	●
Additional safety requirements for AC/DC supplied ballasts acc. to EN61347-2-3 Annex J	●	●	●	-	●	-
Performance requirements EN60929	●	●	●	●	●	-
Preheat starting	●	●	●	-	●	-
Lamp life acc. to EN60081 / EN60901 [*]	●	●	●	●	●	●
Mains current harmonics, acc. to EN61000-3-2	●	●	●	●	●	●
Radio Frequency Interference, acc. to EN55015	●	●	●	●	●	●
Immunity standard, acc. to EN61547	●	●	●	●	●	●
Vibration test EN60068-2-64 test Fh	●	●	●	●	●	-
Bump test EN60068-2-29 test Eb	●	●	●	●	●	-
Thermal protection class EN61347, C5e	●	●	●	●	●	-
Type of starting; preheat (warm start)	●	●	●	●	●	-
EBLF (Emergency Ballast Lumen Factor)	-	-	>0,3	-	-	-
BLF (Ballast Lumen Factor)	-	-	~1	-	-	~1

* EN 60081 for T5 & T8 fluorescent lamps, EN 60901 for compact fluorescent lamps

Ballast lifetime EL-ngn5 range

Type	W	Ta = 40 °C		Ta = 50 °C		Ta = 60 °C		Ta = 65 °C	
		Tc (°C)	Lifetime (h)	Tc (°C)	Lifetime (h)	Tc (°C)	Lifetime (h)	Tc (°C)	Lifetime (h)
EL1x14-35ngn5	1 x 14	43	>100 000	54	>100 000	64	≥100 000	-	-
EL1x14-35ngn5	1 x 21	44	>100 000	55	>100 000	65	≥100 000	-	-
EL1x14-35ngn5	1 x 28	47	>100 000	58	>100 000	68	≥100 000	-	-
EL1x14-35ngn5	1 x 35	49	>100 000	59	>100 000	69	80 000	-	-
EL1x24ngn5	1 x 24	51	>100 000	61	>100 000	71	80 000	-	-
EL1x39/36ngn5	1 x 36	55	>100 000	65	>100 000	75	70 000	-	-
EL1x39/36ngn5	1 x 39	55	>100 000	65	>100 000	75	70 000	-	-
EL1x49ngn5	1 x 49	52	>100 000	62	>100 000	72	70 000	-	-
EL1x54ngn5	1 x 54	53	>100 000	63	>100 000	73	65 000	-	-
EL1x55ngn5	1 x 55	55	>100 000	65	>100 000	75	70 000	-	-
EL1x80ngn5	1 x 80	55	>100 000	65	>100 000	75	60 000	-	-
EL2x14-35ngn5	2 x 14	49	>100 000	59	>100 000	69	>100 000	-	-
EL2x14-35ngn5	2 x 21	50	>100 000	60	>100 000	70	>100 000	-	-
EL2x14-35ngn5	2 x 28	52	>100 000	63	>100 000	73	80 000	-	-
EL2x14-35ngn5	2 x 35	55	>100 000	65	>100 000	75	60 000	-	-
EL2x24ngn5	2 x 24	50	>100 000	60	>100 000	70	70 000	-	-
EL2x39/36ngn5	2 x 39	55	>100 000	65	>100 000	75	60 000	-	-
EL2x39/36ngn5	2 x 36	55	>100 000	65	>100 000	75	60 000	-	-
EL2x49ngn5	2 x 49	55	>100 000	65	>100 000	75	60 000	-	-
EL2x49ngn5-XL	2 x 49	60	>100 000	70	>100 000	80	90 000	85	60 000
EL2x54ngn5	2 x 54	65	>100 000	75	60 000	-	-	-	-
EL2x54ngn5 -XL	2 x 54	60	>100 000	70	>100 000	80	90 000	85	60 000
EL2x55ngn5	2 x 55	60	>100 000	70	60 000	-	-	-	-
EL2x80ngn5	2 x 80	65	>100 000	75	60 000	-	-	-	-
EL3/4x14ngn5	3 x 14	52	>100 000	62	>100 000	72	80 000	-	-
EL3/4x14ngn5	4 x 14	55	>100 000	65	>100 000	75	60 000	-	-
EL4x14ngn5	4 x 14	55	>100 000	65	>100 000	75	60 000	-	-
EL3/4x24ngn5	3 x 24	50	>100 000	60	>100 000	70	90 000	-	-
EL3/4x24ngn5	4 x 24	55	>100 000	65	>100 000	75	65 000	-	-

Ballast lifetime EL-ngn range

Type	W	Ta = 40 °C		Ta = 50 °C		Ta = 60 °C	
		Tc (°C)	Lifetime (h)	Tc (°C)	Lifetime (h)	Tc (°C)	Lifetime (h)
EL1x15ngn	1x15	55	> 100 000	65	> 100 000	75	> 100 000
EL1x18ngn	1 x 18	48	> 100 000	58	> 100 000	68	> 100 000
EL1x30ngn	1x30	55	> 100 000	65	> 100 000	75	> 100 000
EL1x36ngn	1 x 36	50	> 100 000	60	> 100 000	70	> 100 000
EL1x58ngn	1 x 58	61	> 100 000	71	65 000		
EL2x18ngn	2 x 18	52	> 100 000	62	> 100 000	72	90 000
EL2x36ngn	2 x 36	55	> 100 000	65	> 100 000	75	60 000
EL2x58ngn	2 x 58	65	> 100 000	75	60 000		
EL3/4x18ngn	3 x 18	53	> 100 000	63	> 100 000		
EL3/4x18ngn	4 x 18	56	> 100 000	66	90 000		
EL4x18ngn	4 x 18	58	> 100 000	68	65 000		

MAGNETIC BALLASTS

HELVAR has over 6 decades of experience in designing, manufacturing and delivering efficient ballasts for fluorescent and HID lamps - now also in energy efficiency class A2.

The know-how has turned into successful partnerships with luminaire manufacturers and benefits our customers world wide.

High quality is the key element in HELVAR ballasts. Meeting international standards and local regulations are the natural starting points in our: approach to quality – but it does not end there! Whether noise levels, service life, magnetic stray fields or terminal design are concerned, high technical standards are our main objectives in product development. Fully automatic high-volume production and 100 % quality control are ways in which we achieve the top quality in our products.

Offering

HELVAR's fluorescent ballast range offers products to all relevant energy efficiency classes including A2. This gives flexibility to luminaire designers and end users to make the right choices for each application and market sector. The flexibility in HELVAR's production philosophy and product design, as well as the know-how to benefit from different materials, gives the right means to react to the latest demands in energy efficiency classification.

HELVAR manufactures ballasts for all main HID lamp types. The high quality of HELVAR HID ballasts is guaranteed due to uncompromising material selection and 100 % testing of products.



Magnetic ballasts for fluorescent T8 lamps

15 - 58 W 230 V, 50 Hz

- Meets EN 61347-2-8 & EN60921 requirements
- Low harmonics
- Correctly trimmed lamp current guaranteed for entire lifetime
- 100 % quality controlled
- Double wire terminals without screws
- Long lifetime



Lamp			Ballast						Compensation			
Lamp type	Lamp wattage (W)	No. of lamps	Lamp current (A)	Ballast type	EEL	Dimen- sions (p.41)	Convec- tion (p.41)	Net weight (kg)	Inductive λ	Temp. rise Δt (°C)	Parallel Ck 230/250V ±10 % (μF)	Mains current (A)
T8	15	1	0.31	L 15 A-P 230 V 50 Hz	B2	1	1,2	0.55	0.31	50/95	4.0	0.12
	15	1	0.31	L 15 A 230 V 50 Hz	B2	1	1,2	0.60	0.35	55/80	4.0	0.12
	15	2	0.350	L 30 LUA 230 V 50 Hz	A2	10	11	1.2	0.47	25	4.5	0.20
	15	2	0.31	L 30 A 230 V 50 Hz	B2	1	4	0.61	0.50	55/110	4.5	0.20
	15	2	0.31	L 30 A-P 230 V 50 Hz	B2	1	4	0.56	0.50	50/125	4.5	0.21
	16	1	0.20	L 16 DL 230 V 50 Hz	B1	7	1,2	0.32	0.43	60/150	2.0	0.11
	16	1	0.20	L 16 D 230 V 50 Hz	B2	7	1,2	0.32	0.46	65/150	2.0	0.11
	18	1	0.37	L 18 A-T 230 V 50 Hz	B2	1	1,2	0.57	0.32	50/95	4.5	0.14
	18	1	0.37	L 18 A-K 230 V 50 Hz	B2	1	1,2	0.61	0.32	50/95	4.5	0.14
	18	1	0.37	L 18 A-L 230 V 50 Hz ¹⁾	C	1	1,2	0.51	0.35	65/90	4.5	0.14
	18	2	0.37	L 36 LUA 230 V 50 Hz	A2	9	12	1.2	0.45	30	4.5	0.22
	18	2	0.37	L 36 A-K 230 V 50 Hz	B2	1	4	0.61	0.50	50/145	4.5	0.23
	18	2	0.37	L 36 A-T 230 V 50 Hz	B2	1	4	0.57	0.50	50/155	4.5	0.23
	18	2	0.37	L 40 A-C 230 V 50 Hz ¹⁾	C	1	4	0.53	0.53	55/160	4.5	0.23
	18	2	0.37	L 40 A-P 230 V 50 Hz	C	1	4	0.55	0.5	55/155	4.5	0.22
	18	2	0.37	L 2x18 A-TA 230 V 50 Hz	A2	2	4	0.98	0.5	30	4.5	0.23
	18	2	0.37	L 2x18 A-L 230 V 50 Hz	B2	1	4	0.51	0.55	65	4.5	0.23
	25	1	0.29	L 15 A 230 V 50 Hz	B2	1	1,2	0.60	0.50	40/80	3.5	0.15
	25	1	0.29	L 15 A-P 230 V 50 Hz	B2	1	1,2	0.55	0.46	40/95	3.5	0.15
	30	1	0.365	L 30 LUA 230 V 50 Hz	A2	10	11	1.2	0.42	25	4.5	0.19
	30	1	0.365	L 30 A 230 V 50 Hz	B2	1	1,2	0.61	0.45	55/110	4.5	0.19
	30	1	0.365	L 30 A-P 230 V 50 Hz	B2	1	1,2	0.56	0.45	50/125	4.5	0.18
	36	1	0.43	L 36 LUA 230 V 50 Hz	A2	9	11	1.2	0.41	30	4.5	0.23
	36	1	0.43	L 36 A-K 230 V 50 Hz	B2	1	1,2	0.61	0.45	50/145	4.5	0.23
	36	1	0.43	L 36 A-T 230 V 50 Hz	B2	1	1,2	0.57	0.45	50/155	4.5	0.23
	36	1	0.35	L 36 A-L 230 V 50 Hz	D	1	1,2	0.51	0.53	70/165	4.5	0.23
	36	1	0.43	L 40 A-C 230 V 50 Hz ¹⁾	C	1	1,2	0.53	0.50	55/160	4.5	0.23
	36	1	0.43	L 40 A-P 230 V 50 Hz	C	1	1,2	0.51	0.5	55/155	4.5	0.23
	36	1	0.43	L 40 A-L 230 V 50 Hz ¹⁾	D	1	1,2	0.51	0.50	65/160	4.5	0.23
	38	1	0.43	L 36 A-K 230 V 50 Hz	B2	1	1,2	0.61	0.48	50/145	4.5	0.24
38	1	0.43	L 36 A-T 230 V 50 Hz	B2	1	1,2	0.57	0.45	50/155	4.5	0.24	
38	1	0.43	L 40 A-C 230 V 50 Hz ¹⁾	C	1	1,2	0.53	0.50	55/160	4.5	0.24	
58	1	0.67	L 58 LUA 230 V 50 Hz	A2	9	11	1.4	0.43	30	7.0	0.34	
58	1	0.67	L 58 A-K 230 V 50 Hz	B2	2	1,2	0.92	0.48	45/135	7.0	0.34	
58	1	0.67	L 58 A-T 230 V 50 Hz	B2	2	1,2	0.88	0.48	50/145	7.0	0.34	
58	1	0.67	L 65 A-P 230 V 50 Hz ¹⁾	C	2	1,2	0.87	0.50	55/145	7.0	0.34	

Note: See page 41 for connection diagrams, dimensions and delivery information. See page 63 for ENEC approved combinations.

1) Not available for European Union market

2) Lamps excluded from the CELMA EEL directive do not have an EEL classification

Magnetic ballasts for fluorescent T8 lamps

15-125 W 220 V, 240 V 50 Hz

- Meets EN 61347-2-8 & EN60921 requirements
- Low power harmonics
- Correctly trimmed lamp current guaranteed for entire lifetime
- 100 % quality controlled
- Double wire terminals without screws
- Long lifetime



Lamp				Ballast							Compensation		
Lamp type	Lamp wattage (W)	No. of lamps	Lamp current (A)	Ballast type	Voltage (V)	EEL	Dimensions (p.41)	Connection (p.41)	Net weight (kg)	Inductive λ	Temp. rise Δt (°C)	Parallel Ck 230/250V $\pm 10\%$ (μF)	Mains current (A)
T8	18	1	0.37	L18 A-L 220 V 50 Hz ³⁾	220	C	1	1,2	0.51	0.35	65/90	4.5	0.16
	18	2	0.37	L40 A-P 220 V 50 Hz ³⁾	220	C	1	4	0.51	0.53	55/155	4.5	0.23
	18	2	0.37	L36 A-L 220 V 50 Hz ³⁾	220	D	1	4	0.51	0.56	65/160	4.5	0.23
	18	2	0.37	L2x18 A-L 220 V 50 Hz	220	B2	1	4	0.48	0.56	65	4.5	0.24
	18	2	0.37	L40 A-L 220 V 50 Hz ³⁾	220	C	1	4	0.51	0.55	65/160	4.5	0.24
	36	1	0.43	L40 A-P 220 V 50 Hz	220	C	1	1,2	0.51	0.5	55/155	4.5	0.24
	36	1	0.35	L36 A-L 220 V 50 Hz ³⁾	220	D	1	1,2	0.51	0.54	65/160	4.5	0.24
	36	1	0.43	L40 A-L 220 V 50 Hz ³⁾	220	D	1	1,2	0.51	0.50	65/160	4.5	0.24
	38	1	0.43	L40 A-L 220 V 50 Hz ³⁾	220	D	1	1,2	0.51	0.49	65/160	4.5	0.24
	58	1	0.67	L65 A-P 220 V 50 Hz ³⁾	220	C	2	1,2	0.88	0.50	55/145	7.0	0.35
	15	1	0.31	L15 A 240 V 50 Hz	240	B2	1	1,2	0.60	0.35	55/80	4.0	0.11
	15	2	0.31	L30 A-P 240 V 50 Hz	240	B2	1	4	0.56	0.45	55/125	4.0	0.17
	15	2	0.31	L30 A 240 V 50 Hz	240	B2	1	4	0.61	0.45	55/125	4.0	0.17
	16	1	0.2	L16 D 240 V 50 Hz	240	B2	7	2	0.32	0.45	65/160	2.0	0.10
	18	1	0.37	L18 A-K 240 V 50 Hz	240	B2	1	1,2	0.61	0.32	55/90	4.0	0.13
	18	2	0.37	L36 LUA 240 V 50 Hz	240	A2	9	12	1.2	0.44	30	4.5	0.21
	18	2	0.37	L36 A-K 240 V 50 Hz	240	B2	1	4	0.61	0.50	55/155	4.0	0.22
	18	2	0.37	L36 A-T 240 V 50 Hz	240	B2	1	4	0.57	0.52	55/155	4.0	0.22
	18	2	0.37	L40 A-P 240 V 50 Hz ³⁾	240	C	1	4	0.56	0.53	70/160	4.0	0.22
	18	2	0.37	L2x18 A-TA 240 V 50 Hz	240	A2	2	4	0.98	0.48	30	4.0	0.22
	25	1	0.29	L15 A 240 V 50 Hz	240	B2	1	1,2	0.60	0.45	55/90	3.0	0.14
	30	1	0.365	L30 A 240 V 50 Hz	240	B2	1	1,2	0.61	0.45	55/125	4.0	0.17
	30	1	0.365	L30 A-P 240 V 50 Hz	240	B2	1	1,2	0.56	0.45	55/125	4.0	0.17
	36	1	0.43	L36 LUA 240 V 50 Hz	240	A2	9	11	1.2	0.4	30	4.5	0.22
	36	1	0.43	L36 A-K 240 V 50 Hz	240	B2	1	1,2	0.61	0.45	55/155	4.5	0.22
	36	1	0.43	L36 A-T 240 V 50 Hz	240	B2	1	1,2	0.57	0.47	55/155	4.5	0.22
	36	1	0.43	L40 A-P 240 V 50 Hz ³⁾	240	C	1	1,2	0.56	0.50	70/160	4.5	0.22
	38	1	0.43	L36 A-K 240 V 50 Hz	240	B2	1	1,2	0.61	0.45	55/155	4.0	0.23
	38	1	0.43	L36 A-T 240 V 50 Hz	240	B2	1	1,2	0.57	0.49	55/155	4.0	0.23
	38	1	0.43	L40 A-P 240 V 50 Hz ³⁾	240	C	1	1,2	0.56	0.52	70/160	4.0	0.23
	58	1	0.67	L58 LUA 240 V 50 Hz	240	A2	9	11	1.4	0.42	35	7.0	0.32
	58	1	0.67	L58 A-K 240 V 50 Hz	240	B2	2	1,2	0.92	0.48	50/145	7.0	0.32
58	1	0.67	L58 A-T 240 V 50 Hz	240	B2	2	1,2	0.88	0.48	55/145	7.0	0.32	
70	1	0.70	L75 LUA 240 V 50 Hz	240	A2	9	11	1.4	0.47	30	6.0	0.41	
70	1	0.70	L75 A-S 240 V 50 Hz	240	B2	2	1,2	1.00	0.51	60	6.0	0.41	

Note: See page 41 for connection diagrams, dimensions and delivery information. See page 63 for ENEC approved combinations.

1) Essential: Series capacitor 7.2 $\mu F \pm 4\%$ 440 V

2) Capacitive

3) Not available for European Union market

4) Lamps excluded from the CELMA EEL directive do not have an EEL classification

Magnetic ballasts for fluorescent T8 lamps**18-36 W 220 V, 230 V 60 Hz**

- Meets EN 61347-2-8 & EN60921 requirements
- Low power harmonics
- Correctly trimmed lamp current guaranteed for entire lifetime
- 100 % quality controlled
- Double wire terminals without screws
- Long lifetime



CE tw 130

Lamp type	Lamp			Ballast type	Ballast					Compensation		
	Lamp wattage (W)	No. of lamps	Lamp current (A)		Voltage (V)	Dimensions (p.41)	Connec-tion (p.41)	Net weight (kg)	Inductive λ	Temp. rise Δt (°C)	Parallel Ck 230/250V $\pm 10\%$ (μF)	Mains current (A)
T8	18	1	0.37	L 18 A-L 220 V 60 Hz	220	1	1,2	0.51	0.35	60/90	4.0	0.13
	18	1	0.37	L 20 A 220 V 60 Hz	220	1	1,2	0.6	0.35	45/70	4.0	0.13
	18	2	0.37	L 40 A-L 220 V 60 Hz	220	1	4	0.51	0.55	60/130	4.0	0.21
	36	1	0.43	L 40 A-L 220 V 60 Hz	220	1	1,2	0.51	0.5	60/130	4.0	0.22
	36	1	0.43	L 40 A 230 V 60 Hz	230	1	1,2	0.61	0.43	45	4.0	0.22

Note: See page 41 for connection diagrams, dimensions and delivery information. See page 63 for ENEC approved combinations.

1) Essential: Series capacitor 7.2 $\mu F \pm 4\%$ 440 V

2) Capacitive

3) Not available for European Union market

4) Lamps excluded from the CELMA EEL directive do not have an EEL classification

Magnetic ballasts for compact fluorescent lamps

5 - 36 W 230 V, 240 V, 50 Hz

- Meets EN 61347-2-8 & EN 60921 requirements
- 100 % quality controlled
- Double wire terminals without screws
- Low harmonics
- Very low magnetic field
- Long lifetime



Lamp				Ballast						Compensation			
Lamp type	Lamp wattage	No. of lamps	Lamp current	Ballast type	Voltage	EEL	Dimen-sions	Connec-tion	Net weight	Inductive	Temp. rise	Parallel Ck	Mains current
	(W)		(A)		(V)		(p.41)	(p.41)	(kg)	λ	Δt (°C)	230/250V $\pm 10\%$	(A)
TC-L	18	1	0.37	L 18 A-K 230 V 50 Hz	230	B2	1	5	0.61	0.32	55/95	4.5	0.15
	18	1	0.37	L 18 A-T 230 V 50 Hz	230	B2	1	5	0.57	0.32	50/95	4.5	0.15
	18	1	0.37	L 18 A-K 240 V 50 Hz	240	B2	1	5	0.61	0.32	55/90	4.0	0.15
	18	1	0.37	L 18 A-L 230 V 50 Hz ¹⁾	230	C	1	5	0.51	0.35	65/90	4.5	0.15
	18	1	0.37	L 20 A-P 240 V 50 Hz ¹⁾	240	C	1	5	0.56	0.35	60/90	4.0	0.15
	18	2	0.37	L 36 A-K 230 V 50 Hz	230	B2	1	6	0.61	0.50	50/145	4.5	0.23
	18	2	0.37	L 36 A-T 230 V 50 Hz	230	B2	1	6	0.57	0.50	50/155	4.5	0.23
	18	2	0.37	L 36 A-K 240 V 50 Hz	240	B2	1	6	0.61	0.50	55/155	4.0	0.21
	18	2	0.37	L 36 A-T 240 V 50 Hz	240	B2	1	6	0.57	0.52	55/155	4.0	0.21
	18	2	0.37	L 40 A-C 230 V 50 Hz ¹⁾	230	C	1	6	0.53	0.53	55/160	4.5	0.23
	18	2	0.37	L 40 A-P 240 V 50 Hz ¹⁾	240	C	1	6	0.56	0.53	70/160	4.0	0.21
	18	2	0.37	L 40 A-L 230 V 50 Hz ¹⁾	230	D	1	6	0.51	0.55	65/160	4.5	0.23
	24	1	0.345	L 18 A-K 230 V 50 Hz	230	B2	1	5	0.61	0.40	55/95	4.0	0.16
	24	1	0.345	L 18 A-T 230 V 50 Hz	230	B2	1	5	0.57	0.38	50/95	4.0	0.16
	24	1	0.345	L 18 A-L 230 V 50 Hz ¹⁾	230	C	1	5	0.51	0.42	65/90	4.0	0.16
	24	1	0.345	L 20 A-P 240 V 50 Hz ¹⁾	240	C	1	5	0.56	0.42	60/90	3.5	0.15
	36	1	0.43	L 36 A-K 230 V 50 Hz	230	B2	1	5	0.61	0.45	50/145	4.5	0.23
	36	1	0.43	L 36 A-T 230 V 50 Hz	230	B2	1	5	0.57	0.45	50/155	4.5	0.23
	36	1	0.43	L 36 A-K 240 V 50 Hz	240	B2	1	5	0.61	0.45	55/155	4.0	0.22
	36	1	0.43	L 36 A-T 240 V 50 Hz	240	B2	1	5	0.57	0.47	55/155	4.5	0.22
36	1	0.43	L 40 A-C 230 V 50 Hz ¹⁾	230	C	1	5	0.53	0.50	55/160	4.5	0.23	
36	1	0.43	L 40 A-P 240 V 50 Hz ¹⁾	240	C	1	5	0.56	0.50	70/160	4.0	0.22	
TC-S	5	1	0.18	L 11 D 230 V 50 Hz	230	B2	7	7	0.32	0.25	60/85	2.0	0.07
	5	1	0.18	L 11 D 240 V 50 Hz	240	B2	7	7	0.32	0.25	65/90	2.0	0.06
	5	2	0.18	L 13 DL 230 V 50 Hz	230	B1	7	8	0.32	0.35	50/95	2.0	0.08
	5	2	0.18	L 13 D 230 V 50 Hz	230	B1	7	8	0.32	0.40	65/120	2.0	0.08
	5	2	0.18	L 13 D 240 V 50 Hz	240	B2	7	8	0.32	0.40	65/110	2.0	0.08
	7	1	0.18	L 11 D 230 V 50 Hz	230	B2	7	7	0.32	0.28	60/85	2.0	0.07
	7	1	0.18	L 11 D 240 V 50 Hz	240	B2	7	7	0.32	0.30	65/90	2.0	0.07
	7	2	0.18	L 13 DL 230 V 50 Hz	230	B1	7	8	0.32	0.45	50/95	2.0	0.09
	7	2	0.18	L 13 D 230 V 50 Hz	230	B1	7	8	0.32	0.45	65/120	2.0	0.09
	7	2	0.18	L 13 D 240 V 50 Hz	240	B2	7	8	0.32	0.45	65/110	2.0	0.09
	9	1	0.17	L 11 D 230 V 50 Hz	230	B2	7	7	0.32	0.33	60/85	2.0	0.07
	9	1	0.17	L 11 D 240 V 50 Hz	240	B2	7	7	0.32	0.33	65/90	2.0	0.07
	9	2	0.17	L 13 DL 230 V 50 Hz	230	B1	7	8	0.32	0.55	50/95	2.0	0.10
	9	2	0.17	L 13 D 230 V 50 Hz	230	B1	7	8	0.32	0.55	65/120	2.0	0.10
	9	2	0.17	L 13 D 240 V 50 Hz	240	B2	7	8	0.32	0.55	65/110	2.0	0.10
	11	1	0.155	L 11 D 230 V 50 Hz	230	B2	7	7	0.32	0.43	60/85	2.0	0.08
11	1	0.155	L 11 D 240 V 50 Hz	240	B2	7	7	0.32	0.43	65/90	2.0	0.08	

Note: See page 41 for connection diagrams, dimensions and delivery information. See page 63 for ENEC approved combinations.

1) Not available for European Union market

Magnetic ballasts for compact fluorescent lamps

4 - 38 W 230 V, 240 V, 50 Hz

- Meets EN 61347-2-8 & EN 60921 requirements
- 100 % quality controlled
- Double wire terminals without screws
- Low harmonics
- Very low magnetic field
- Long lifetime



Lamp				Ballast							Compensation		
Lamp type	Lamp wattage (W)	No. of lamps	Lamp current (A)	Ballast type	EEL	Dimensions (p.41)	Connection (p.41)	Net weight (kg)	Inductive λ	Temp. rise Δt (°C)	Parallel Ck 230/250V $\pm 10\%$ (μF)	Mains current (A)	
T5	4	1	0.17	L 8 D 230 V 50 Hz	230	B2	7	1	0.32	0.25	65/90	2.0	0.06
	4	1	0.17	L 8 D 240 V 50 Hz	240	B2	7	1	0.32	0.25	60/90	2.0	0.05
	4	2	0.17	L 8 D 230 V 50 Hz	230	B2	7	4	0.32	0.35	65/90	2.0	0.06
	4	2	0.17	L 8 D 240 V 50 Hz	240	B2	7	4	0.32	0.35	60/90	2.0	0.06
	6	1	0.16	L 8 D 230 V 50 Hz	230	B2	7	1	0.32	0.30	65/90	2.0	0.06
	6	1	0.16	L 8 D 240 V 50 Hz	240	B2	7	1	0.32	0.30	60/90	2.0	0.05
	6	2	0.16	L 13 DL 230 V 50 Hz	230	B1	7	4	0.32	0.45	50/95	2.0	0.08
	6	2	0.16	L 13 D 230 V 50 Hz	230	B1	7	4	0.32	0.45	65/120	2.0	0.08
	6	2	0.16	L 13 D 240 V 50 Hz	240	B2	7	4	0.32	0.45	65/110	2.0	0.08
	8	1	0.145	L 8 D 230 V 50 Hz	230	B2	7	1	0.32	0.33	65/90	2.0	0.06
	8	1	0.145	L 11 D 230 V 50 Hz	230	B2	7	1	0.32	0.33	60/85	2.0	0.06
	8	1	0.145	L 8 D 240 V 50 Hz	240	B2	7	1	0.32	0.33	60/90	2.0	0.06
	8	1	0.145	L 11 D 240 V 50 Hz	240	B2	7	1	0.32	0.33	65/90	2.0	0.06
	8	2	0.145	L 13 DL 230 V 50 Hz	230	B1	7	4	0.32	0.50	50/95	2.0	0.10
	8	2	0.145	L 16 DL 230 V 50 Hz	230	B1	7	4	0.32	0.43	60/150	2.0	0.11
	8	2	0.145	L 16 D 230 V 50 Hz	230	B2	7	4	0.32	0.50	65/150	2.0	0.11
8	2	0.145	L 16 D 240 V 50 Hz	240	B2	7	4	0.32	0.45	65/90	2.0	0.10	
13	1	0.165	L 13 DL 230 V 50 Hz	230	B1	7	1	0.32	0.45	50/95	2.0	0.10	
13	1	0.165	L 13 D 230 V 50 Hz	230	B1	7	1	0.32	0.45	65/120	2.0	0.10	
13	1	0.165	L 13 D 240 V 50 Hz	240	B2	7	1	0.32	0.45	65/110	2.0	0.08	
TC-D	10	1	0.19	L 13 DL 230 V 50 Hz	230	B2	7	7	0.32	0.35	50/95	2.0	0.08
	10	1	0.19	L 13 D 230 V 50 Hz	230	B2	7	7	0.32	0.35	65/120	2.0	0.08
	10	1	0.19	L 13 D 240 V 50 Hz	240	B2	7	7	0.32	0.35	65/110	2.0	0.08
	13	1	0.175	L 13 DL 230 V 50 Hz	230	B1	7	7	0.32	0.45	50/95	2.0	0.08
	13	1	0.175	L 13 D 230 V 50 Hz	230	B1	7	7	0.32	0.45	65/120	2.0	0.08
	13	1	0.175	L 13 D 240 V 50 Hz	240	B2	7	7	0.32	0.45	65/110	2.0	0.08
	18	1	0.22	L 18 DL 230 V 50 Hz	230	B1	7	7	0.32	0.45	60/150	2.0	0.12
	18	1	0.22	L 18 D 230 V 50 Hz	230	B1	7	7	0.32	0.50	65/155	2.0	0.13
	18	1	0.22	L 18 D 240 V 50 Hz	240	B1	7	7	0.32	0.45	65/155	2.0	0.12
	26	1	0.325	L 18 A-T 230 V 50 Hz	230	B2	1	10	0.57	0.45	50/95	3.5	0.18
	26	1	0.325	L 18 A-K 230 V 50 Hz	230	B2	1	7	0.61	0.45	55/95	3.5	0.18
	26	1	0.325	L 26 S-100mm 230 V 50 Hz	230	B2	8	7	0.44	0.47	60/140	3.5	0.18
	26	1	0.325	L 18 A-K 240 V 50 Hz	240	B2	1	5	0.61	0.43	55/90	3.5	0.17
	26	1	0.325	L 26 S-100 240 V 50 Hz	240	B2	8	7	0.44	0.45	60/150	3.5	0.17
26	1	0.325	L 18 A-L 230 V 50 Hz ¹⁾	230	C	1	7	0.51	0.45	75/90	3.5	0.18	
26	1	0.325	L 20 A-P 240 V 50 Hz ¹⁾	240	C	1	7	0.56	0.45	60/90	3.0	0.17	
TC-DD ²⁾	16	1	0.20	L 16 DL 230 V 50 Hz	230	B1	7	10	0.32	0.43	60/150	2.0	0.11
	16	1	0.20	L 16 D 230 V 50 Hz	230	B2	7	10	0.32	0.46	65/150	2.0	0.11
	16	1	0.195	L 16 D 240 V 50 Hz	240	B2	7	10	0.32	0.45	65/160	2.0	0.11
	28	1	0.325	L 18 A-T 230 V 50 Hz	230	B2	1	10	0.57	0.50	50/95	3.5	0.20
	28	1	0.325	L 18 A-L 230 V 50 Hz ¹⁾	230	C	1	10	0.51	0.50	65/90	3.5	0.20
	38	1	0.43	L 36 A-K 230 V 50 Hz	230	B2	1	10	0.61	0.48	50/145	4.5	0.24
	38	1	0.43	L 36 A-T 230 V 50 Hz	230	B2	1	10	0.57	0.45	50/155	4.5	0.24
	38	1	0.43	L 40 A-C 230 V 50 Hz ¹⁾	230	C	1	10	0.53	0.48	55/160	4.5	0.24
38	1	0.43	L 40 A-L 230 V 50 Hz ¹⁾	230	D	1	10	0.51	0.48	65/160	4.5	0.24	
T-R ³⁾	22	1	0.40	L 30 A 230 V 50 Hz ¹⁾	230	C	1	9	0.61	0.35	60/110	5.0	0.17
	22	1	0.40	L 30 A 240 V 50 Hz	240	B2	1	9	0.51	0.35	60/125	4.5	0.19

Note: See page 41 for connection diagrams, dimensions and delivery information. See page 63 for ENEC approved combinations.

1) Not available for European Union market

2) Also GR 10q; external starter required

3) Cap G10q

Magnetic ballasts for compact fluorescent lamps**6 - 18 W 110 V, 230 V, 60 Hz**

- Meets EN 61347-2-8 & EN 60921 requirements
- 100 % quality controlled
- Double wire terminals without screws
- Low harmonics
- Very low magnetic field
- Long lifetime



CE tw 130

Lamp type	Lamp			Ballast type	Ballast					Compensation		
	Lamp wattage (W)	No. of lamps	Lamp current (A)		Voltage (V)	Dimensions (p.41)	Connection (p.41)	Net weight (kg)	Inductive λ	Temp. rise Δt (°C)	Parallel Ck 230/250V $\pm 10\%$ (μ F)	Mains current (A)
T8	18	1	0.37	L 20D 110 V 60 Hz	110	7	1	0.32	0.54	45/110	8.0	0.15
	6	2	0.16	L 13D 230 V 60 Hz	230	7	4	0.32	0.45	45/110	2.0	0.08
T5	8	1	0.175	L 11D 230 V 60 Hz	230	7	1	0.32	0.33	45/80	2.0	0.06
	13	1	0.165	L 13D 230 V 60 Hz	230	7	1	0.32	0.45	45/110	2.0	0.10
TC-D	10	1	0.19	L 13D 230 V 60 Hz	230	7	5	0.32	0.35	45/110	2.0	0.08
	13	1	0.175	L 13D 230 V 60 Hz	230	7	5	0.32	0.45	45/110	2.0	0.08
	18	1	0.22	L 18D 230 V 60 Hz	230	7	5	0.32	0.5	45/125	2.0	0.12
TC-S	5	1	0.18	L 11D 230 V 60 Hz	230	7	5	0.32	0.23	45/80	2.0	0.06
	5	2	0.18	L 13D 230 V 60 Hz	230	7	6	0.32	0.4	45/110	2.0	0.08
	7	1	0.18	L 11D 230 V 60 Hz	230	7	5	0.32	0.28	45/80	2.0	0.07
	7	2	0.18	L 13D 230 V 60 Hz	230	7	6	0.32	0.45	45/110	2.0	0.09
	9	1	0.17	L 11D 230 V 60 Hz	230	7	5	0.32	0.33	45/80	2.0	0.07
	9	2	0.15	L 13D 230 V 60 Hz	230	7	6	0.32	0.55	45/110	2.0	0.10
	11	1	0.155	L 11D 230 V 60 Hz	230	7	5	0.32	0.43	45/80	2.0	0.07

Note: See page 41 for connection diagrams, dimensions and delivery information. See page 63 for ENEC approved combinations.

Connection diagrams

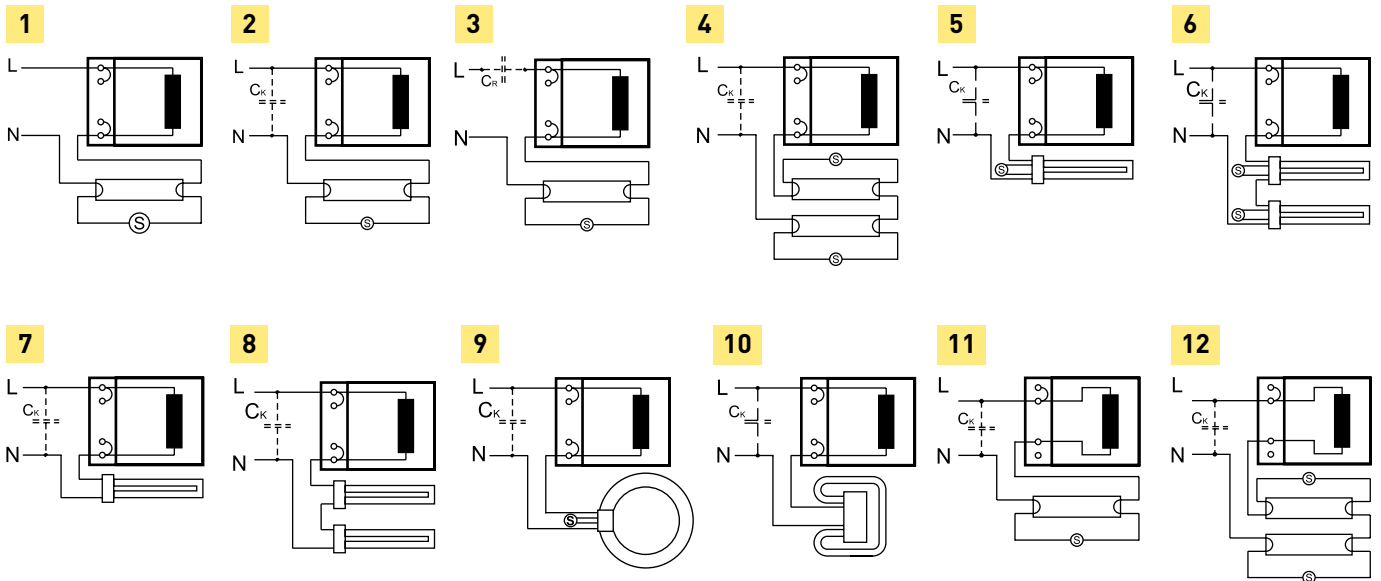

Dimensions

No.	1	2	3	4	5	6	7	8	9	10
Drawing	A	A	B	B	B	B	C	D	E	E
Length 'a' (mm)	150	190	150	230	190	110	85	110	114	114
Width 'b' (mm)	42	42	42	42	42	42	41.5	42	54	54
Height 'c' (mm)	28	28	28.8	28.8	28.8	28.8	28	26	45.5	45.5
'd' (mm)	140	180	140	220	180	100	73	100	105	95

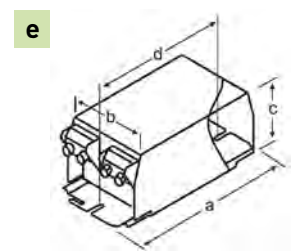
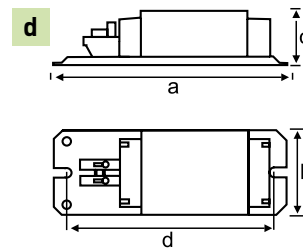
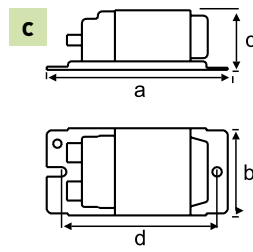
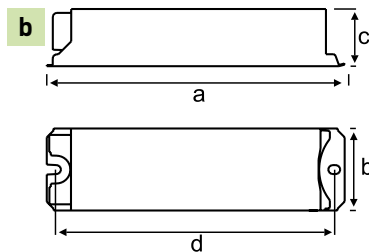
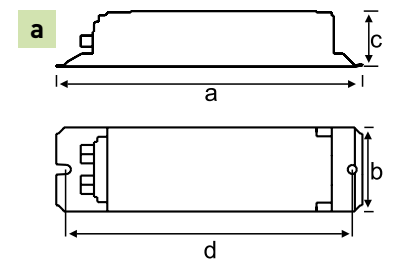

Delivery information

Delivery information									
Ballast	Unit package			Transportation package					
	Minimum delivery amount	Plastic binding strip	Carton box	Eur pallet 1200 x 820 (pcs.)	One-way pallet			Pallet weight (kg)	Pallet height (cm)
			1080 x 770 (pcs.)		730 x 650 (pcs.)	1120 x 730 (pcs.)			
L 18 - 36TL	10	X		1250	1400	840	-	720-1190	53
L...TS / TLD, L 21TL	10	X		2100	1500	-	-	1010-1159	63
L 42 - 100 T/TL/TE	10	X		750	750	-	-	1080	45
L 15 - 40 A...	10	X		2000	2000	960	-	A/AK 602-1256	68
L...D / DL	30		X	1800	-	-	1800	612	40
L 58. - 85 A...	10	X		1200	1200	720	-	720-1215	58
L 26 S-100mm	8	X		2016	-	-	-	925	46

Magnetic ballasts for high pressure mercury lamps

50 - 400 W 220 - 240 V, 50 Hz

- Meets EN 61347-2-9 & EN 60923 requirements
- Very low magnetic field
- 100 % quality controlled
- Low power losses
- Low harmonics
- Low noise
- Long lifetime



tw 130 & 140

Lamp			Ballast								Compensation	
Lamp type	Lamp wattage (W)	Lamp current (A)	Ballast type	Voltage	BEC /EEI ¹⁾	Dimen- sions (p.51)	Convec- tion (p.50)	Net weight (kg)	Inductive λ	Temp. rise Δt (°C)	Parallel Ck 230/250V ±10 % (μF)	Mains current (A)
	80/50	0.80/0.62	E 80/50LU 230/240 V 50 Hz	230 240	EEI=A3	1	2	1.22	0.50/0.42	70/65	8	0.45/0.30
	125/80	1.15/0.80	E 125/80LU 230/240 V 50 Hz	230 240	EEI=A3	1	2	1.22	0.55/0.50	70/60	10	0.70/0.45
	125/80	1.15/0.80	E 125/80LUP 230 V 50 Hz	230	EEI=A3	1	1	1.22	0.55/0.50	70/60	10	0.70/0.45
	125	1.15	E 125 LU 220 V 50 Hz	220	EEI=A3	1	4	1.21	0.55	70	10	0.70
	125	1.15	E 125 LU 230 V 50 Hz	230	EEI=A3	1	4	1.22	0.55	70	10	0.70
	250	2.13	E 250 SE 230 V 50 Hz ³⁾	230	A2	8	5	1.86	0.55	75	18	1.40
	250	2.13	E 250 SE 240 V 50 Hz ³⁾	240	A2	8	5	1.86	0.55	75	18	1.40
	250	2.13	E 250 T, F 230 V 50 Hz ^{2) 4) 5)}	230	A2	2,5	7	2.10	0.55	65	18	1.40
	250	2.13	E 250 T 230/240 V 50 Hz ^{2) 4) 5)}	230 240	A2	2	9	2.10	0.55	65 70	18	1.40
	400	3.25	E 400 SE 230 V 50 Hz ⁴⁾	230	A2	10	5	3.00	0.57	75	25	2.15
HM	400	3.25	E 400 SE 240 V 50 Hz ⁴⁾	240	A2	10	5	3.00	0.56	75	25	2.15
	400	3.25	E 400 T 220 V 50 Hz ^{2) 4) 5)}	220	A2	6	6	3.16	0.60	70	25	2.15
	400	3.25	E 400 T 230 V 50 Hz ^{2) 4) 5)}	230	A2	3	7	3.16	0.60	65	25	2.15
	400	3.25	E 400 F 230/240 V 50 Hz ^{2) 4) 5)}	230 240	A2	6	18	3.16	0.60	65 70	25	2.15
	400	3,25	E 400 TLC 220/230 V 50 Hz ^{2) 4) 5)}	220 230	A2	4	12	3.6	0.58	55	25	2.15
	400	3,25	E 400 TLC 230/240 V 50 Hz ^{2) 4) 5)}	230 240	A2	4	9	3.7	0.56	55 60	25	2.15
	400	3,25	E 400 TLPC 230/240 V 50 Hz ^{2) 4) 5)}	230 240	A2	4	10	3.7	0.56	55 60	25	2.15
	400	3.25	E 400 TP, FP 230/240 V 50 Hz ^{2) 4) 5)}	230 240	A2	3,6	10	3.16	0.60	65 70	25	2.15
	400	3.25	E 400 TL 220/230 V 50 Hz ^{2) 4) 5)}	220 230	A2	4	9	3.0	0.59	65 70	25	2.15
	400	3.25	E 400 TL 230/240 V 50 Hz ^{2) 4) 5)}	230 240	A2	4	11	3.1	0.57	70	25	2.15
	400	3.25	E 400 TLP 230/240 V 50 Hz ^{2) 4) 5)}	230 240	A2	4	12	3.1	0.57	70	25	2.15

1) BEC = Ballast efficiency class, EEI = Energy Efficiency Index

2) T-type = two and four point fixing

F-type = four point fixing

3) With push-in terminals

4) With screw terminals

5) Product has tw140

Note: P in ballast type name means built-in thermal protector (eg. E400 TP or NK70LUPK)

Magnetic ballasts for high pressure sodium lamps

50-70 W 220 - 240 V, 50 Hz

- Meets EN 61347-2-9 & EN 60923 requirements
- Very low magnetic field
- 100 % quality controlled
- Low power losses
- Low harmonics
- Low noise
- Long lifetime



Lamp			Ballast							Compensation		
Lamp type	Lamp wattage (W)	Lamp current (A)	Ballast type	Voltage	BEC / EEI ¹⁾	Dimensions (p.51)	Connection (p.50)	Net weight (kg)	Inductive λ	Temp. rise Δt (°C)	Parallel Ck 230/250V ±10% (μF)	Mains current (A)
	50	0,76	NK 50 LUAP 230 V 50 Hz	230	A2	15	29	1.4	0.34	40	8	0.33
	50	0.76	NK 50 LUP 230/240 V 50 Hz	230 240	EEI=A3	1	15	1.22	0.38	70	8.0	0.33
	70	1.0	NK 70 LUAP 230/240 V 50 Hz	230 240	A2	15	3	1.4	0.35	55	12	0.43
	70	1.0	NK 70 LU 220 V 50 Hz	220	EEI=A3	1	4	1.22	0.39	70	12	0.43
	70	1.0	NK 70 LU 220/230 V 50 Hz	220 230	EEI=A3	1	3	1.22	0.4	75	12	0.43
	70	1.0	NK 70 LUPK 220/230 V 50 Hz	220 230	EEI=A3	1	3	1.22	0.39	65	12	0.43
	70	1.0	NK 70 LU 230/240 V 50 Hz	230 240	EEI=A3	1	13	1.22	0.39	70	12.0	0.43
HS	70	1.0	NK 70 LUP 230/240 V 50 Hz	230 240	EEI=A3	1	15	1.22	0.39	70	12.0	0.43
	70	1.0	NK 70 LUE 220 V 50 Hz	220	EEI=A3	1	28	1.18	0.39	75	12.0	0.43
	70	1.0	NK 70 LUE 230/240 V 50 Hz	230 240	EEI=A3	1	13	1.22	0.38 0.36	75 80	12.0	0.43
	70	1.0	NK 70 LUPE 230/240 V 50 Hz	230 240	EEI=A3	1	15	1.20	0.38 0.36	75 80	12.0	0.43
	70	1.0	NK 70 LUPK 230/240 V 50 Hz	230 240	EEI=A3	1	15	1.22	0.39	65	12.0	0.43
	70/50	1.0/0.76	NK 70/50 LU 230/240 V 50 Hz	230 240	EEI=A3	1	14	1.22	0.39/0.38	75/60	12.0/8.0	0.43/0.33
	70/50	1.0/0.76	NK 70/50 LUP 230 V 50 Hz	230	EEI=A3	1	15	1.22	0.39/0.38	75/60	12.0/8.0	0.43/0.33
	70/50	1/0.76	NK 70/50 LUP 240 V 50 Hz	240	EEI=A3	1	24	1.22	0.39/0.38	75/60	12	0.43

1) BEC = Ballast efficiency class, EEI = Energy Efficiency Index

Note: P in ballast type name means built-in thermal protector (eg. E400 TP or NK70LUPK)

Magnetic ballasts for high pressure sodium lamps

- Meets EN 61347-2-9 & EN 60923 requirements
- Very low magnetic field
- 100 % quality controlled
- Low power losses
- Low harmonics
- Low noise
- Long lifetime

70-150 W 220 - 240 V, 50 Hz



Lamp			Ballast								Compensation	
Lamp type	Lamp wattage (W)	Lamp current (A)	Ballast type	Voltage	BEC / EEI ¹⁾	Dimensions (p.51)	Connection (p.50)	Net weight (kg)	Inductive λ	Temp. rise Δt (°C)	Parallel Ck 230/250V ±10 % (μF)	Mains current (A)
	100	1.2	NK 100 LUAP 230 V 50 Hz	230	A2	15	29	1.4	0.42	65	12	0.56
	100	1.2	NK 100 SEAP 230/240 V 50 Hz	230 240	A2	13	15	1.4	0.4	70	12	0.56
	100	1.2	NK 100 LU 230 V 50 Hz	230	EEI=A3	1	4	1.22	0.44	75	12	0.9
	100	1.2	NK 100 LU 230/240 V 50 Hz	230 240	EEI=A3	1	13	1.22	0.44	80	12.0	0.56
	100	1.2	NK 100 LUP 230/240 V 50 Hz	230 240	EEI=A3	1	13	1.22	0.44	80	12.0	0.56
	100/70	1.2/1.0	NK 100/70 SEP 230 V 50 Hz	230	EEI=A3	13	15	1.27	0.41/0.35	75/65	12.0/12.0	0.56/0.43
	150	1.8	NK 150 TLAP 230/240 V 50 Hz ²⁾	230 240	A2	3	18	2.8	0.39	50	20	0.9
	150	1.8	NK 150 SEAP 230/240 V 50 Hz	230 240	A2	10	15	3.0	0.38	50	20	0.9
HS	150	1.8	NK 150 SE 110-120 mm 220 V 50 Hz	220	EEI=A3	16	23	1.85	0.4	75	20	0.9
	150	1.8	NK 150 TL 220/230 V 50 Hz ²⁾	220 230	EEI=A3	3	18	1.80	0.41	75	20	0.9
	150	1.8	NK 150 TL 230/240 V 50 Hz ²⁾	230 240	EEI=A3	3	21	1.80	0.40	75	20	0.9
	150	1.8	NK 150 SE 220 V 50 Hz ⁴⁾	220	EEI=A3	11	23	1.8	0.40	75	20	0.9
	150	1.8	NK 150 SE 230/240 V 50 Hz	230 240	EEI=A3	8	15	1.85	0.41	75	20	0.9
	150	1.8	NK 150 SEP 230/240 V 50 Hz ³⁾	230 240	EEI=A3	8	15	1.85	0.41	75	20	0.9
	150	1.8	NK 150 SEP 110-120 mm 230/240 V 50 Hz	230 240	EEI=A3	16	15	1.85	0.41	75	20	0.9
	150	1.8	NK 150 SEPK 230/240 V 50 Hz	230 240	EEI=A3	9	15	2.6	0.40	65	20	0.9
	150/100	1.8/1.2	NK 150/100 SEP 230/240 V 50 Hz	230 240	EEI=A3	9	30	2.6	0.38 0.37	60/35	20/12	0.9/0.56

1) BEC = Ballast efficiency class, EEI = Energy Efficiency Index

2) Product has tw140

3) Available also with bottom length 133 mm

4) With push-in terminals

Note: P in ballast type name means built-in thermal protector (eg. E400 TP or NK70LUPK)

Magnetic ballasts for high pressure sodium lamps

- Meets EN 61347-2-9 & EN 60923 requirements
- Very low magnetic field
- 100 % quality controlled
- Low power losses
- Low harmonics
- Low noise
- Long lifetime
- Multiple fixing point variations

250-1000 W 220 - 240 V, 50 Hz



Lamp			Ballast							Compensation			
Lamp type	Lamp wattage (W)	Lamp current (A)	Ballast type	Voltage	BEC / EEI ¹⁾	Dimensions (p.51)	Connection (p.50)	Net weight (kg)	Inductive λ	Temp. rise Δt (°C)	Parallel Ck 230/250V ±10 % (μF)	Mains current (A)	
	250	3.0	NK 250 T 220 V 50 Hz	220	EEI=A3	3	25	3.15	0.42	70	32	1.4	
	250	3.0	NK 250 SEL 220 V 50 Hz	220	EEI=A3	10	23	2.6	0.42	80	32	1.4	
	250	3.0	NK 250 TLK 220/230 V 50 Hz	220 230	EEI=A3	3	21	2.75	0.43	75	32	1.4	
	250	3.0	NK 250 TAP 230/240 V 50 Hz ^{2) 3)}	230 240	A2	3	19	3.3	0.4	65	32	1.4	
	250	3.0	NK 250 SEP 230/240 V 50 Hz	230 240	EEI=A3	10	15	3.00	0.38	75 80	32	1.4	
	250	3.0	NK 250 T 230 V 50 Hz ^{2) 3)}	230	EEI=A3	3,6	16	3.15	0.42	70	32	1.4	
	250	3.0	NK 250 T, F 230/240 V 50 Hz ^{2) 3)}	230 240	EEI=A3	3,6	18	3.15	0.42	70 75	32	1.4	
	250	3.0	NK 250 TLC 220/230 V 50 Hz ^{2) 3)}	220 230	EEI=A3	4	18	3	0.44	65	32	1.4	
	250	3.0	NK 250 TLPC 230/240 V 50 Hz ^{2) 3)}	230 240	EEI=A3	4	21	3	0.42	65	32	1.4	
	250	3.0	NK 250 TP, FP 230/240 V 50 Hz ^{2) 3)}	230 240	EEI=A3	3,6	19	3.15	0.42	70 75	32	1.4	
	250	3.0	NK 250 TLK 220/230 V 50 Hz ³⁾	220 230	EEI=A3	3	21	2.75	0.43	75	32	1.4	
	250	3.0	NK 250 TLK 230/240 V 50 Hz ³⁾	230 240	EEI=A3	3	18	2.75	0.43	75 80	32	1.4	
	250	3.0	NK 250 TLPK 230/240 V 50 Hz ³⁾	230 240	EEI=A3	3	19	2.75	0.43	75 80	32	1.4	
HS	400	4.4	NK 400 T 230/240 V 50 Hz ^{2) 3)}	230 240	A2	4	18	4.4	0.40	70 75	50	2.2	
	400	4.4	NK 400 TP, FP 230/240 V 50 Hz ^{2) 3)}	230 240	A2	4,7	19	4.4	0.40	70 75	50	2.2	
	400	4.4	NK 400 FE 230/240 V 50 Hz ^{2) 3)}	230 240	EEI=A3	4,7	21	3.6	0.41	75	50	2.2	
	400	4.4	NK 400 TE 220 V 50 Hz ^{3) 5)}	220	A2	4	26	3.6	0.43	75	50	2.2	
	400	4.4	NK 400 TE 130 mm 230/240 V 50 Hz ^{2) 3)}	230 240	EEI=A3	17	22	4.4	0.43	75	50	2.2	
	400	4.4	NK 400 TEP, FEP 230/240 V 50 Hz ^{2) 3)}	230 240	EEI=A3	4,7	22	3.6	0.41	75	50	2.2	
	400	4.4	NK 400 T 220 V 50 Hz ^{2) 3) 5)}	220	A2	4	25	4.4	0.40	70	50	2.2	
	400	4.4	NK 400 F 230 V 50 Hz	230	EEI=A3	7	16	4.4	0.4	70	50	2.2	
	400	4.4	NK 400 FP 240 V 50 Hz	240	EEI=A3	7	31	4.4	0.4	75			
	400	4.4	NK 400 TL 220/230 V 50 Hz ^{2) 3) 7)}	220 230	EEI=A3	4	18	3.8	0.44 0.42	80	50	2.2	
	400	4.4	NK 400 TLP 220/230 V 50 Hz ^{2) 3) 7)}	220 230	EEI=A3	4	19	3.8	0.44 0.42	80	50	2.2	
	600	6.2	NK 600 TA/2 230/240 V 50 Hz ^{2) 3) 4)}	230 240	A2	4	20	9.0	0.45	50	65	3	
	600	6.2	NK 600 T/2 230/240 V 50 Hz ^{2) 3) 4)}	230 240	EEI=A3	6	20	6.3	0.44	75 80	65	3.0	
	600	6.2	NK 600 TL/2 220 V 50 Hz	220	EEI=A3	4	27	5.5	0.48	65	65	3	
	600	6.2	NK 600 SE 230 V 50 Hz	230	A2	14	23	6.9	0.47	75	65	3.0	
	1000	10.3/9.5	NK/H 1000 T/2 220 V 50 Hz ^{3) 4)}	220 (NK) 6) 220 (H) 6)	EEI=A3	4	20	8.8	0.45 0.49	80 70	100	5.0	
1000	10.3	NK 1000 F/2 230/240 V 50 Hz ^{2) 3) 4)}	230 240	EEI=A3	7	20	8.8	0.45	80	100	5.3 5.0		

1) BEC = Ballast efficiency class, EEI = Energy Efficiency Index

2) T-type = two and four point fixing F-type = four point fixing

3) Product has tw140

4) Supplied as 2 identical ballasts both with the dimensions indicated. All other technical values are stated for the combined product operating one lamp.

5) Can also be used with certain 400 W HI-lamps. Check lamp manufacturers data to ensure they specify that the lamp is suitable for HPS ballast

6) NK-output for high pressure sodium lamps, H-output for metal halide lamps

7) Not ENEC approved

Note: P in ballast type name means built-in thermal protector (eg. NK400 TP or NK600 SEP)

Power reduction ballasts for high pressure sodium lamps

50 - 400 W 230 V, 50 Hz

- Meets EN 61347-2-9 & EN 60923 requirements
- Very low magnetic field
- 100 % quality controlled
- Low power losses
- Low harmonics
- Low noise
- Long lifetime



Lamp		Ballast type	Circuit power ³⁾		BEC / EEI ⁵⁾	Luminous flux (Φ) reduction	Circuit power reduction	Dimen- sions (p.51)	Connec- tion (p.50)	Net weight (kg)	Inductive λ	Temp. rise Δt (°C)	Compensation	
Lamp wattage (W)	Lamp current (A)		Full (W)	Reduced (W)									Parallel Ck 230/250V ±10 % (μF)	Mains current (A)
70	1.0	NK 70/50LUP 230 V 50 Hz ²⁾	84	59	EEI=A3	~50%	29%	1	24	1.22	0.39	75	12.0	0.43
100	1.2	NK 100/70SEP 230 V 50 Hz ²⁾	115	79	EEI=A3	~50%	32%	13	24	1.27	0.41	75	12.0	0.56
150	1.8	NK 150/50% SEP 230 V 50 Hz	166	107	EEI=A3	~50%	36%	8	24	1.85	0.43	75	20	0.90
250	3.0	NK 250/50% SEP 230 V 50 Hz ¹⁾	274	171	EEI=A3	~50%	38%	12	24	3.4	0.41	75	32	1.4
400	4.4	NK 400/50% TP 230 V 50 Hz ⁴⁾	434	288	A2	~50%	34%	4	24	4.4	0.40	75	50	2.2

1) Not ENEC approved

2) Can also be used as a bi-power ballast, see page 43

3) Measured with a certain operating lamp openly mounted. Measurement results may vary from lamp to lamp

4) Product has tw140

5) BEC = Ballast efficiency class, EEI = Energy Efficiency Index

Note: P in ballast type name means built-in thermal protector (eg. NK100/70SEP)

Operating instructions

The circuit power can be reduced by using a power reduction ballast with extra tapping for higher impedance, together with a power reduction switch. Lamps must always be ignited with the higher rated wattage of a ballast and not switched down to reduced wattage before 10 minutes of normal operation after the ignition of a lamp.

Magnetic ballasts for metal halide lamps

- Meets EN 61347-2-9 & EN 60923 requirements
- Very low magnetic field
- 100 % quality controlled
- Low power losses
- Low harmonics
- Low noise
- Long lifetime
- Multiple fixing point variations

35-150 W 220 - 240 V, 50 Hz



tw 130 & 140

Lamp			Ballast								Compensation	
Lamp type	Lamp wattage (W)	Lamp current (A)	Ballast type	Voltage	BEC / EEI ¹⁾	Dimensions (p.51)	Connec- tion (p.50)	Net weight (kg)	Inductive λ	Temp. rise Δt (°C)	Parallel Ck 230/250V ±10 % (μF)	Mains current (A)
HI	35	0.53	NK 35 LU 230/240 V 50 Hz	230/240	EEI=A3	1	13	1.22	0.38	50	6	0.23
	35	0.53	NK 35 LUP 230/240 V 50 Hz	230/240	EEI=A3	1	15	1.22	0.38	50	6.0	0.33
	50	0.76	NK 50 LUAP 230 V 50 Hz	230	A2	15	29	1.4	0.34	40	8	0.33
	50	0.76	NK 50 LU 230/240 V 50 Hz ⁶⁾	230/240	EEI=A3	1	13	1.22	0.38	70	8	0.33
	50	0.76	NK 50 LUP 230/240 V 50 Hz ⁶⁾	230/240	EEI=A3	1	15	1.22	0.38	70	8	0.33
	70/50	1.0/0.76	NK 70/50 LU 230/240 V 50 Hz ⁶⁾	230/240	EEI=A3	1	14	1.22	0.39/0.38	75/60	12.0/8.0	0.43/0.33
	70/50	1.0/0.76	NK 70/50 LUP 230 V 50 Hz ⁶⁾	230	EEI=A3	1	15	1.22	0.39/0.38	75/60	12.0/8.0	0.43/0.33
	70	1	NK 70 LU 220 V 50 Hz	220	EEI=A3	1	4	1.22	0.39	70	12	0.43
	70	1.0	NK 70 LU 240 V 50 Hz	240	EEI=A3	1	28	1.22	0.39	70	12.0	0.43
	70	1	NK 70 LUAP 230/240 V 50 Hz	230/240	A2	15	3	1.4	0.35	55	12	0.43
	70	1.0	NK 70 LUP 230/240 V 50 Hz	230/240	EEI=A3	1	15	1.22	0.39	70	12.0	0.43
	70	1.0	NK 70 LUPK 240 V 50 Hz	240	EEI=A3	1	29	1.22	0.39	65	12.0	0.43
	70	1.0	NK 70 LUPK 230/240 V 50 Hz	230/240	EEI=A3	1	15	1.22	0.39	65	12.0	0.43
	70	1.0	NK 70 LUE 220 V 50 Hz	220	EEI=A3	1	28	1.18	0.39	75	12.0	0.43
	70	1	NK 70 LUE 230 V 50 Hz	230	EEI=A3	1	4	1.2	0.38	75	12	0.43
	70	1.0	NK 70 LUE 230/240 V 50 Hz	230/240	EEI=A3	1	13	1.22	0.38/0.36	75/80	12.0	0.56
	70	1.0	NK 70 LUPE 230/240 V 50 Hz	230/240	EEI=A3	1	15	1.20	0.38/0.36	75/80	12.0	0.56/0.43
	100	1.2	NK 100 LUAP 230 V 50 Hz	230	A2	15	29	1.4	0.42	65	12	0.56
	100	1.2	NK 100 LU 230 V 50 Hz	230	EEI=A3	1	4	1.22	0.44	75	12	0.56
	100	1.1	NK 100 LUP 230/240 V 50 Hz	230/240	EEI=A3	1	13	1.22	0.44	80	12.0	0.9
	100/70	1.1/1.0	NK 100/70 SEP 230 V 50 Hz	230	EEI=A3	13	13	1.27	0.41/0.35	75/65	12.0/12.0	0.9
	150	1.8	NK 150 TLAP 230/240 V 50 Hz ²⁾³⁾	230/240	A2	3	18	2.8	0.39	50	20	0.9
	150	1.8	NK 150 SEAP 230/240 V 50 Hz	230/240	A2	10	15	3	0.38	50	20	0.9
	150	1.8	NK 150 TL 220/230 V 50 Hz ²⁾³⁾	220/230	EEI=A3	3	18	1.80	0.41	75	20	0.9
	150	1.8	NK 150 TL 230/240 V 50 Hz ²⁾³⁾	230/240	EEI=A3	3	21	1.80	0.40	75	20	0.9
	150	1.8	NK 150 SEP 230/240 V 50 Hz ⁴⁾⁵⁾	230/240	EEI=A3	8	15	1.85	0.41	75	20	0.9
	150	1.8	NK 150 SEPK 230/240 V 50 Hz ⁴⁾	230/240	EEI=A3	9	15	2.6	0.40	65	20	0.9
	150	1.8	NK 150 SE 110-120 mm 220 V 50 Hz	220	EEI=A3	16	23	1.85	0.4	75	20	0.9
	150	1.8	NK 150 SEP 110-120 mm 230/240 V 50 Hz	230/240	EEI=A3	16	15	1.85	0.41	75	20	0.9

1) BEC = Ballast efficiency class, EEI = Energy Efficiency Index
 2) T-type = two and four point fixing, F-type = four point fixing
 3) Product has tw140
 4) With push-in terminals

5) Available also with bottom length 133 mm
 6) 50 W : Only suitable with CDO lamps
 Note: P in ballast type name means built-in thermal protector (eg. NK70LUPK)

Magnetic ballasts for metal halide lamps

- Meets EN 61347-2-9 & EN 60923 requirements
- Very low magnetic field
- 100 % quality controlled
- Low power losses
- Low harmonics
- Low noise
- Long lifetime
- Multiple fixing point variations

250-1000 W 220 - 240 V, 50 Hz



Lamp			Ballast								Compensation	
Lamp type	Lamp wattage (W)	Lamp current (A)	Ballast type	Voltage	BEC /EEI ¹⁾	Dimen- sions (p.51)	Connec- tion (p.50)	Net weight (kg)	Inductive λ	Temp. rise Δt (°C)	Parallel Ck 230/250V ±10 % (μF)	Mains current (A)
HI	250	3.0	NK 250 T 220 V 50 Hz	220	EEI=A3	3	25	3.15	0.42	70	32	1.4
	250	3.0	NK 250 TLK 220/230 V 50 Hz ⁵⁾	220 230	EEI=A3	3	21	2.75	0.43	75	32	1.4
	250	3.0	NK 250 TAP 230/240 V 50 Hz ⁵⁾	230 240	A2	3	19	3.3	0.4	65	32	1.4
	250	3.0	NK 250 TLK 230/240 V 50 Hz ⁵⁾	230 240	EEI=A3	3	18	2.75	0.43	75 80	32	1.4
	250	3.0	NK 250 TLPK 230/240 V 50 Hz ⁵⁾	230 240	EEI=A3	3	19	2.75	0.43	75 80	32	1.4
	250	3.0	NK 250 SEL 220 V 50 Hz	220	EEI=A3	10	23	2.6	0.42	80	32	1.4
	250	3.0	NK 250 SEP 230/240 V 50 Hz	230 240	EEI=A3	10	15	3.00	0.38	75 80	32	1.4
	250	3.0	NK 250 TP, FP 230/240 V 50 Hz ^{2) 5)}	230 240	EEI=A3	3,6	19	3.15	0.42	70 75	32	1.4
	400	3.5	E 400 SE 230 V 50 Hz	230	A2	10	23	3.00	0.51	80	35	2.2
	400	3.5	E 400 SE 240 V 50 Hz	240	A2	10	23	3.00	0.49	80	35	2.2
	400	4.1	NK 400 F 230 V 50 Hz	230	EEI=A3	7	16	4.4	0.4	70	45	2.2
	400	4.1	NK 400 FP 240 V 50 Hz	240	EEI=A3	7	31	4.4	0.4	75	45	2.2
	400	4.1	NK 400 TP, FP 230/240 V 50 Hz ^{2) 4) 5)}	230 240	A2	4,7	19	4.40	0.40	70 75	45	2.2
	400	4.1	NK 400 FE 230/240 V 50 Hz ^{2) 4) 5)}	230 240	A2	7	21	3.6	0.41	75	45	2.2
	400	4.1	NK 400 TE 130 mm 230/240 V 50 Hz ⁵⁾	230 240	A2	17	22	4.4	0.43	75	45	2.2
	400	4.1	NK 400 TEP, FEP 230/240 V 50 Hz ^{2) 4) 5)}	230 240	A2	4,7	22	3.6	0.41	75	45	2.2
	400	4.1	NK 400 TL, TLP 220/230 V 50 Hz ^{2) 5) 7)}	220 230	EEI=A3	4	18,19	3.8	0.44 0.42	80	45	2.2
	400	3.5	H 400 T 230/240 V 50 Hz ^{2) 5)}	230 240	A2	3	18	3.18	0.48	70 75	35	2.2
	400	3.5	H 400 TP 230/240 V 50 Hz ^{2) 5)}	230 240	A2	3	22	3.18	0.48	70 75	35	2.2
	400	3.5	E 400 TLC 220/230 V 50 Hz ^{2) 5)}	220 230	A2	4	21	3.6	0.55	65	35	2.15
	400	3.5	E 400 TLC 230/240 V 50 Hz ^{2) 5)}	230 240	A2	4	18	3.7	0.53	65	35	2.15
	400	3.5	E 400 TLPC 230/240 V 50 Hz ^{2) 5)}	230 240	A2	4	19	3.7	0.53	65	35	2.15
	400	3.5	E 400 T 220 V 50 Hz ^{2) 5)}	220	A2	3	25	3.15	0.49	80	35	2.15
	400	3.5	E 400 T 230 V 50 Hz ^{2) 5)}	230	A2	3	16	3.16	0.49	80	35	2.15
	400	3.5	E 400 F 230/240 V 50 Hz ^{2) 5)}	230 240	A2	6	18	3.16	0.49	80	35	2.15
	400	3.5	E 400 TL 220 V 50 Hz ^{2) 5)}	220	A2	4	17	3.0	0.53	75	35	2.15
	400	3.5	E 400 TL 220/230 V 50 Hz ⁵⁾	220 230	A2	4	18	3.0	0.55	75	35	2.15
	400	3.5	E 400 TLP 230/240 V 50 Hz ⁵⁾	230 240	A2	4	22	3.1	0.53	75 80	35	2.15
	400	3.5	E 400 TP, FP 230/240 V 50 Hz ^{2) 5)}	230 240	A2	3,6	22	3.16	0.49	80	35	2.15
	1000	10.3/9.5	NK/H 1000 T/2 220 V 50 Hz ^{3) 5)}	220 (NK) 6) 220 (H)	A2	4	20	8.8	0.45 0.49	80 70	100	5.0
	1000	9.5	H 1000 F/2 230/240 V 50 Hz ^{2) 3) 5)}	230 240	EEI=A3	4	20	8.8	0.49	85	100	4.6

1) BEC = Ballast efficiency class, EEI = Energy Efficiency Index

2) T-type = two and four point fixing, F-type = four point fixing

3) Supplied as 2 identical ballasts both with the dimensions indicated. All other technical values are stated for the combined product operating one lamp

4) Check lamp manufacturers data to ensure they specify that the lamp is suitable for HPS ballast

5) Product has tw140

6) NK-output for high pressure sodium lamps, H-output for metal halide lamps

7) Not ENEC approved

Note: P in ballast type name means built-in thermal protector (eg. E400 TP or NK70LUPK)

Magnetic ballasts for high intensity discharge lamps

- Meets EN 61347-2-9 & EN 60923 requirements
- Very low magnetic field
- 100 % quality controlled
- Low power losses
- Low harmonics
- Low noise
- Long lifetime

50-1000 W 220 V, 230V 60 Hz



CE tw 130 & 140

Lamp			Ballast							Compensation	
Lamp type	Lamp wattage (W)	Lamp current (A)	Ballast type	Voltage (V)	Dimensions (p.51)	Connection (p.50)	Net weight (kg)	Inductive λ	Temp. rise Δt (°C)	Parallel Ck 230/250V $\pm 10\%$ (μF)	Mains current (A)
HS / HI	50	0.76	NK 50 LU 220/230 V 60 Hz ⁵⁾	220 230	1	13	1.22	0.38	70	6	0.33
	70	1.0	NK 70 LU 220/230 V 60 Hz ⁵⁾	220 230	1	13	1.22	0.39	65	10	0.43
	70	1.0	NK 70 LUP 220/230 V 60 Hz ⁵⁾	220 230	1	17	1.22	0.39	65	10	0.43
	100	1.2	NK 100 LU 220 V 60 Hz ⁵⁾	220	1	28	1.22	0.44	75	10	0.56
	150	1.8	NK 150 SEP 220 V 60 Hz ⁵⁾	220	8	23	1.85	0.44	75	16	0.9
	150	1.8	NK 150 TL 220 V 60 Hz ^{2) 6)}	220	2	25	1.8	0.42	75	16	0.9
	250	3.0	NK 250 TLC 220 V 60 Hz ^{2) 6)}	220	3	25	2.75	0.45	65	25	1.4
	250	3.0	NK 250 TLK 220 V 60 Hz ^{2) 6)}	220	3	17	2.75	0.42	65	25	1.4
	250	3.0	NK 250 T 220 V 60 Hz ^{2) 6)}	220	3	17	3.15	0.42	65	25	1.4
	HS	400	4.4	NK 400 TE 220 V 60 Hz ^{2) 6)}	220	4	25	3.6	0.45	80	40
400		4.4	NK 400 TL 220 V 60 Hz ^{2) 6)}	220	4	17	3.7	0.45	80	40	2.2
400		4.4	NK 400 T 220 V 60 Hz ^{2) 6)}	220	4	17	4.4	0.47	65	40	2.2
1000		10.3	NK 1000 F/2 220 V 60 Hz ^{3) 4) 6)}	220	7	27	8.8	0.45	80	80	5.3
HI	400	3.5	E 400 TL 220/230 V 60 Hz ^{2) 6)}	220 230	4	11	3	0.56 0.54	75	25	2.15
	1000	9.5	H 1000 F/2 220 V 60 Hz ^{3) 4) 6)}	220	7	27	8.8	0.51	80	80	4.6
HM	400	3.25	E 400 TL 220/230 V 60 Hz ^{2) 6)}	220 230	4	11	3	0.56 0.54	75	20	2.15

1) Winding at 25 °C

2) T-type = two and four point fixing

3) F-type = four point fixing

4) Supplied as 2 identical ballasts both with the dimensions indicated

All other technical values are stated for the combined product operating one lamp

5) With push-in terminals

6) Product has tw140

HID-ballasts

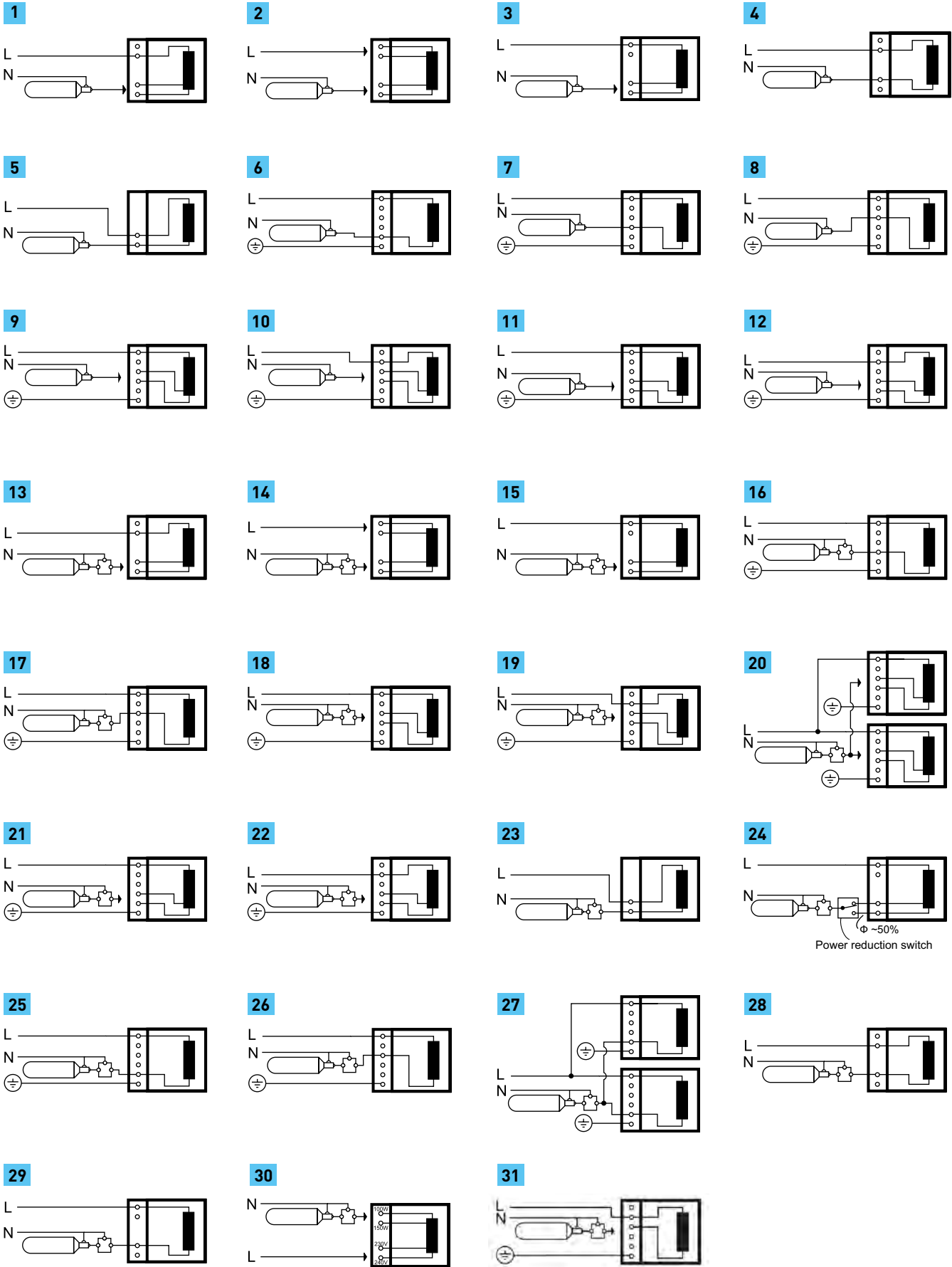

NO.	1	2	3	4	5	6	7	8	9	10	11	12	13	14	15	16	17
DRAWING	a	b	b	b	c	c	c	d	d	d	d	e	f	e	a	d	b
LENGTH 'a' (mm)	114	135	135	165	104	104	135	145	160	180	133	133	112	173	114	133	144
WIDTH 'b' (mm)	54	70	70	70	70	70	70	69	69	69	69	104	69	104	54	69	70
HEIGHT 'c' (mm)	45.5	85	85	85	85	85	85	53	53	53	53	90.5	53	90.5	45.5	53	85
'd' (mm)	95	120	120	150	90	90	100	120	140	155	120	120	95	160	105	110-120	130
'e' (mm)		35	35	35	90	90	100										35
'f' (mm)		85	108	138	85	108	138										138
'g' (mm)					80	80	90										

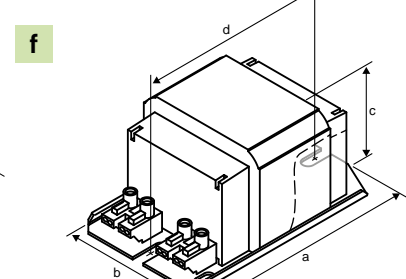
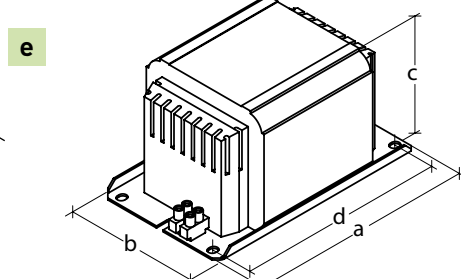
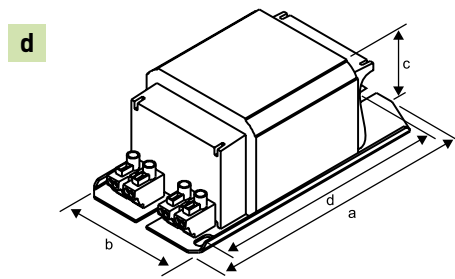
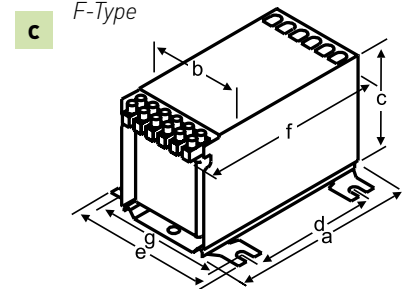
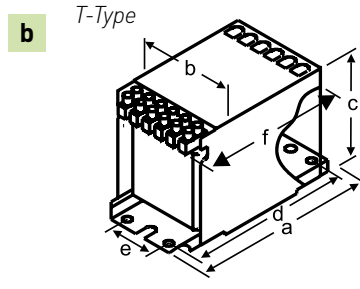
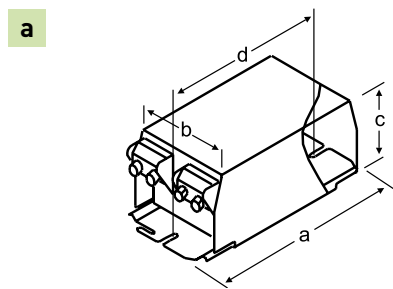

Delivery information								
Ballast	Unit package			Transportation package				
	Minimum delivery amount	Plastic binding strip	Carton box	EURO pallet 1200 x 800	One-way pallet 730 x 650 (pcs.)	One-way pallet 730 x 1120 (pcs.)	Pallet weight (kg)	Pallet height (cm)
E-LU, E-LUP	4	●			432	960	527 - 1170	50
E...LU/LUP/LUS	4	●			432	960	527-1170	50
NK ...LU/LUP/LUS								
E250 - 400T								
H400T	5		●			300	530-750	48
NK250T								
E250 - 400F								
H400F	4		●			240	530-1060	48
NK250F								
NK400T/F, NK400/50% TP								
E...SE/SEP								
NK100/70SEP	3	●		360-450-630			820-910	50-55
NK150-250SE/SEP								
NK250/50% SEP	2	●		200			710	54
NK600 T,F/2								
NK1000 T,F/2	2*		●			120 (240)	760-1060	48
H1000 F/2								

Electronic superimposed pulse ignitors

Helvar

freedom in lighting

- Fully electronic
- Super-imposed pulse type
- Compact design
- Solid metal fixing screw
- Low inherent heating
- High thermal resistance
- Low power losses
- ENEC approved

220-240 V, 50-60 Hz



	Max. contin. lamp current (A)	Cut out time (min)	Ignition voltage (kV)	Impulse width (µs)	Internal losses (W)
L-70	1	-	1.9 ... 2.3	2 (1.5 kV)	< 1.0 (25 °C; 1 A)
L-150	1.8	-	4.0 ... 4.5	1.4 (2.0 kV)	< 1.0 (25 °C; 1.8 A)
HI-400M	4.6	-	4.0 ... 4.5	1.0 (2.0 kV)	< 3.4 (25 °C; 4.6 A)
HI-400S	4.6	-	4.0 ... 4.5	1.0 (2.0 kV)	< 3.3 (25 °C; 4.6 A)
L-600	6.5	-	4.0 ... 4.5	1.2 (2.0 kV)	< 4.0 (25 °C; 6.5 A)
L-1000S ²⁾	12	-	4.0 ... 4.5	1.5 (2.0 kV)	< 6.0 (25 °C; 12 A)
LSI-70T1	1	2	1.9 ... 2.3	2 (1.5 kV)	<1.0 (25 °C; 1A)
LSI-150T20	1.8	20	4.0 ... 4.5	1.4 (2.0 kV)	<1.0 (25 °C; 1.8 A)
LHI-400ST10	4.6	18	3.5 ... 4.5	1.0 (2.0 kV)	<3.0 (25 °C; 4.6 A)
LSI-400ST20	4.6	DIGITAL	4.0 ... 4.5	0.9 (2.0 kV)	<3.3 (25 °C; 4.6 A)
LSI-600T20	6.5	DIGITAL	4.0 ... 4.5	1.2 (2.0 kV)	<4.0 (25 °C; 6.5 A)
LSI-1000T10 ²⁾	12	18	4.0 ... 4.5	1.7 (2.0 kV)	<6.0 (25 °C; 12 A)

Note: Suitability for lamps refers to most common lamps acc. to EN standards. Check also lamp manufacturer information of proper ignitor selection. Not suitable for lamps with low ignition voltage (~1 kV)

1) See also recommended combinations, dimensions and connection on page 53

2) Not ENEC approved

Minimum delivery amount 50 pcs.

Technical Data

Operating voltage	198-264 V, 50-60 Hz
Cut-out voltage	≤ 170 V
Phasing	60-90 / 240-270 °el
Pulses per half cycle	3 *
Max. load capacitance	100 pF **
Max. housing temp.	105 °C
Min. ambient temp.	- 30 °C

*) 2 for L-70 & LSI-70T1

**) 200 for L-70 & LSI-70T1

Connection

Terminals: 3-pole D-L-N 2.5 mm² max

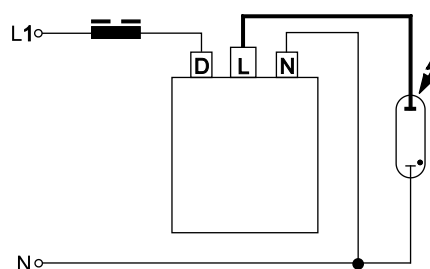

Additional specifications and cut-out sequence for LSI-400ST20 & LSI-600T20

- Intelligent timer with µC for light source protection and energy saving operation
- Protective against power-line overvoltage
- Lamp protection during ignition
- Continuous lamp-state check
- Stable ignition over a wide temperature range
- Radio-frequency interference level 10 % to standard timed version
- Long life performance
- Approval to EN 61347, EN 60927, EN 55014

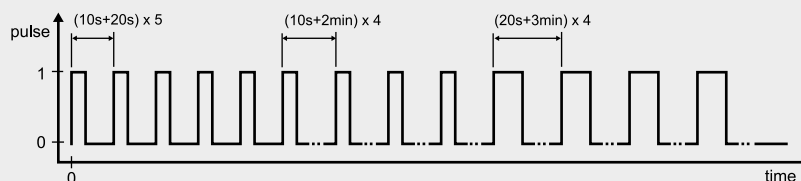

Ignitor	HIGH PRESSURE SODIUM									CERAMIC METAL HALIDE						METAL HALIDE ¹⁾								
	Watt	35	50	70	100	150	250	400	600	1000	35	70	100	150	250	400	35	70	100	150	250	400	1000	
L-70																								
LSI-70T1																								
L-150			DE ³⁾																					
LSI-150T20			DE ³⁾																					
HI-400M			DE ³⁾							2)	2)					2)	2)							
HI-400S			DE ³⁾							2)	2)					2)	2)							
LHI-400ST10			DE ³⁾							2)	2)					2)	2)							
LSI-400ST20			DE ³⁾							2)	2)					2)	2)							
L-600			DE ³⁾	2)	2)					2)	2)					2)	2)	2)	2)					
LSI-600T20			DE ³⁾	2)	2)					2)	2)					2)	2)	2)	2)					
L-1000S			DE ³⁾	2)	2)					2)	2)	2)	2)			2)	2)	2)	2)					
LSI-1000T10			DE ³⁾	2)	2)					2)	2)	2)	2)			2)	2)	2)	2)					

Recommended combination

- T1 Automatic cut-out 2 min
- T10 Automatic cut-out 18 min
- T20 Automatic cut-out 20 min

Note: Suitability for lamps refers to most common lamps acc. to EN standards. Check also lamp manufacturer information of proper ignitor selection.

- 1) Not suitable for lamps with low ignition voltage (~1 kV)
- 2) Used combination
- 3) DE means double ended lamp

Dimensions

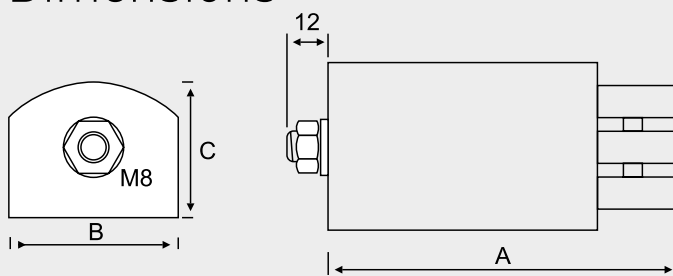

Ignitor	A X B X C (mm)	Weight (g)
L-70	88x34x28	130
L-150	88x34x28	130
HI-400M	92x34x28	130
HI-400S	92x38x32	160
L-600	92x43x36	230
L-1000 / L-1000S	108x55x43	460
LSI-70T1	88x34x28	130
LSI-150T20	88x34x28	130
LHI-400ST10	92x38x32	160
LSI-400ST20	92x38x32	160
LSI-600T20	92x43x36	230
LSI-1000T10	108x55x43	460

Helvar ballast and ignitors are designed to be built into luminaires. Safe and reliable operation of the components requires that the luminaire complies with the relevant standards and regulations (e.g. IEC 60598-1). The luminaire shall be designed to adequately protect the control gear from dust, moisture and pollution.

The luminaire manufacturer remains responsible for the correct choice and installation of the control gear according to the application. Specifications of the control gear shall not be exceeded when it is used in the luminaire in the actual operating conditions. The ballast shall not be used outside the luminaire.

For further information and troubleshooting please visit: www.helvar.com/downloads/product-documentation/support-documentation

Wiring considerations

Wire type

- Solid core conductor only

Wire cross section dimensions

- 0.5 - 1.5 mm² (EL-s-u 0.5 - 0.75 mm²)

Wiring insulation

- According to recommendations in EN 60598

Maximum wire lengths

- See Characteristics table

Wire connections

- As shown on the ballast label and the Wiring Diagram datasheets

Wire preparation

- Strip length 7.5 mm ± 1 mm

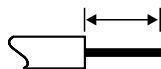

Wiring capacitance

- 80 pF / metre (max. for advised wire lengths)

Wire insertion force

- 8 Newtons (typical)

Wire release from ballast

- (See detailed release instructions on page 168)

Wiring layout

- Keep all wiring as short as possible (particularly the 'Hot' wires - see Wiring Diagrams datasheets)
- 'Hot' wires should be of equal length
- 'Cold' wires should be of equal length
- Always run mains wiring, lamp wiring and low voltage control wiring separate from each other
- Do not run hot and cold lamp wires bunched together
- Lamp wires of two or more separate ballast should not be run together

Installation & operational considerations

Ballast earthing

- EL-s, EL-ngn, EL-ngn5, EL-es and EL-TCs ranges operationally suitable for both Class I & II fittings (no earth required). However to ensure full EMC compatibility a functional earthing might be required
- All other Helvar electronic ballasts require a functional earth to be connected to ensure reliable operation

Maximum tc temperature

- Reliable operation and lifetime is only guaranteed if the maximum tc point temperature is not exceeded under the conditions of use

Frequent switching

- Helvar warm start ballasts may be used in conjunction with occupancy sensors (PIR) as long as the 'OFF' period is greater than 1 minute. Frequently used 'OFF' periods shorter than 1 minute may reduce lamp life

Master / Slave connection

- Not advised

Switching off one lamp via lamp wires

- Not permitted

Starting aid

- For a reliable lamp ignition the use of metal starting aid is recommended
- For reliable starting (and electrical safety) all metal parts of the fitting must be at the same electrical potential as the ballast case

Reflector position

- Placing a reflector or metal plate very close to the lamp may increase RFI emissions and cause excessive leakage current of the fitting
- See lamp standards for recommendations

Fitting components

- Ensure the correct electrical ratings for the lamps are used (e.g. 500V rated lampholders are required for T5 lamps)

Ballast mounting position

- Ensure that the entire length of the ballast lies against a flat surface to ensure good heat dissipation

Installation & operational considerations

Class II luminaires:

Helvar electronic ballasts can be used in suitably designed class II luminaires. The following points must be very carefully noted:

- EL-sc and EL-iDim / EL-iDim-c ballasts must have functional earth connected
- Luminaire standard EN 60598 provides full details of the requirements for class II luminaires
- Starting aid may be required for reliable operating and EMC performance

Lamp “burn in”:

Brand new lamps may occasionally have an uneven distribution of internal gases. This can lead to unreliable starting or uneven light distribution from the lamp. Helvar recommend that new lamps are operated at full output (“burnt in”) for 100 hours prior to being dimmed.

DALI controls:

Currently the DALI standard only governs compatibility of load interfaces such as electronic ballasts and LED drivers. For other units, like sensors and control devices, the compatibility assurance is in process. Until the standard for these is finalised, the total system compatibility must be ensured at the system design / integrator stage.

Stand-by function

The stand-by function is designed specifically as a protection for the ballast. It will switch the lamps off when an ‘end of lifetime’ condition occurs. Lamps can also fail in many other ways. As such, the exact operating state of the ballast under other lamp fault conditions depends on the specific failure. The ballast will not be harmed under any normal lamp failure condition. Ballasts can be reset from stand-by either by switching the mains supply off and then on, or by replacing the faulty lamps.

Lamp ‘end of lifetime’

- Behaviour of the ballast at end of lamp life time: IEC 61347-2-3 17.2.
- If the lamp electrical characteristics (e.g. lamp voltage) exceed the ballast internal preset values, the ballast will recognise that a lamp/s has reached the end of its useful operational life. The ballast will then switch off the supply to the lamps to prevent unnecessary stress to the circuit.

Emergency inverter units

Due to our continuing program of product development and improvement, Helvar ballast designs are evolving constantly. This natural evolution may affect compatibility between our electronic ballasts and emergency conversion modules. It is therefore the responsibility of either the fitting manufacturer, emergency unit supplier and/or system integrator to ensure the used combination is fully compatible.

Emergency inverter unit recommendations

- Use a 4 pole changeover device, with all 4 poles being used to disconnect the lamp.
- Disconnect the mains supply from the ballast before disconnecting the emergency lamp, and prior to the lamps connection to the emergency unit.
- Reconnect the emergency lamp to the ballast before applying the mains supply.
- For multiple lamp ballasts, the wiring lengths for emergency and non-emergency lamps should be equal.

Site considerations

Insulation resistance testing on an installation

- Carry out insulation resistance testing with the fittings disconnected from the mains supply (the fitting has already been tested by the manufacturer)
- If fittings are connected to the mains supply during an insulation resistance test, all Live phases and Neutral must be connected together before the test is carried out.
- Ensure correct reconnection before the mains supply is reapplied.

Mixed technology on the same electrical circuit

- Do not mix magnetic and electronic ballasts on the same electrical circuit. The energy spikes from magnetic ballasts may damage electronic ballasts.

Infra-red (IR) system

- Fluorescent lamps emit not only visible light, but also infra-red light. In some cases this may cause interference to IR systems. To minimise problems the IR system should have a reduced receiving area. To guarantee successful functionality the manufacturer of the IR system should be contacted prior to installation. Helvar ballasts typically operate at frequencies rarely used in IR applications.

3-phase supplies

- Do not apply power to the ballast / fitting without the Neutral conductor connected.
- Do not disconnect the Neutral conductor unless the supply is off.

Miniature Circuit Breakers (Please refer page 59)

- ‘Type C’ MCB’s with trip characteristics in according to EN 60898 are recommended.
- ‘Type B’ MCB’s are not recommended due to their sensitivity. If used, load only to 60 % of the equivalent ‘Type C’ MCB.

Helvar ballast and ignitors are designed to be built into luminaires. Safe and reliable operation of the components requires that the luminaire complies with the relevant standards and regulations (e.g. IEC 60598-1). The luminaire shall be designed to adequately protect the control gear from dust, moisture and pollution.

The luminaire manufacturer remains responsible for the correct choice and installation of the control gear according to the application. Specifications of the control gear shall not be exceeded when it is used in the luminaire in the actual operating conditions. The ballast shall not be used outside the luminaire.

Wiring considerations

1. Fluorescent and HID lamp ballasts

Wire type

- Push in terminals: Solid core conductor only
- Screw terminals: Solid core or stranded conductor

Wiring insulation

- According to recommendations in EN 60598

Wire cross section dimensions

- Push in terminals: 0.5 - 1.0 mm²
(0.5 - 1.5 mm² for HID lamp ballasts)
- Screw terminals: 1.5 - 3.0 mm²

Wire preparation

- Push in terminals: Strip length 8.0 - 9.0 mm

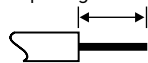

- Screw terminals: Strip length 7.0 mm ± 1 mm

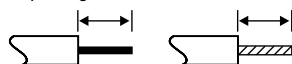

Wire connections

- As shown on the ballast label and the Wiring Diagram datasheets

Mineral insulated cable

- Not advised

Wire release from ballast

- Push in terminals: Use a 1 mm² solid pin (or similar)
- Screw terminals: Flat blade screwdriver

More detailed release instructions on page 62

Wiring layout

Keep all **wiring** as short as possible

- Mains wiring and lamp should always be kept as far as possible from each-other
- Mains wiring should not be bunched together with lamp wiring
- Avoid wiring 'loops' (to minimise magnetic coupling effect)
- Avoid long parallel cable runs

2. Ignitors for HID lamps

Wire type

- Solid core or stranded conductor

Wiring insulation

- According to recommendations in EN 60598

Wire cross section dimensions

- 1.5 - 3.0 mm² or 2.0 - 4.0 mm² (depending upon ignitor type)
- 2.5 - 5.0 mm² (1000 W ignitors)

Wire connections

- As shown on the ignitor label and datasheet

Mineral insulated cable

- Not advised

Wire preparation

- Strip length 7.0 mm ± 1 mm

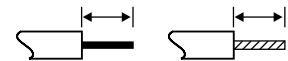

Wire release from ignitor

- Flat blade screwdriver

Wiring layout

- Keep wiring from the ignitor to the lamp as short as possible

Installation & operational considerations

Ballast earthing

- Required for safety

Lifetime

- Reliable operation and lifetime is only guaranteed if the maximum winding temperature of $t_w 130\text{ }^\circ\text{C}$ is not exceeded under the conditions of normal use

Ballast mounting

- The ballast must be located in such a position as to ensure that its maximum winding temperature of $t_w 130\text{ }^\circ\text{C}$ is not exceeded under the conditions of normal use
- Mount the ballast against a flat surface to ensure good heat dissipation

Starting aid

- For reliable starting (and electrical safety) all metal parts of the fitting must be at the same electrical potential as the ballast case

Fitting components

- Ensure the correct electrical ratings for the lamps being used

Ignitor choice

- Helvar ballasts for Metal Halide or High Pressure Sodium lamps are only suitable for use with superimposed pulse type ignitors
- Pulsar type ignitors (where a high starting voltage is applied to the ballast windings) are not suitable for Helvar ballasts. If used, the ballast winding insulation will be subjected to increased load. This will drastically shorten the ballast lifetime

Reflector position

- Situating a reflector or metal plate very close to the lamp may increase RFI emissions and cause excessive leakage current of the fitting

Protection against lamp rectification

- Metal Halide & High-Pressure Sodium lamps can begin to rectify as they reach the end of their operational lifetime. This can cause excessive temperature in a fitting. As such, it is recommended that thermal protection be fitted in these luminaires
- A thermal protection device should be fitted inside the luminaire
- Helvar ballasts for Metal Halide & High-Pressure Sodium lamps are available also with internal thermal protectors (P-types)
- Use of ignitors with a timer facility also provide some protection against lamprerectification. Use in conjunction with a thermal protector

Noise avoidance

- Ensure the ballast is securely fixed within the luminaire
- Fix the ballast at a minimum distance of 3 mm from the side of the fitting
- Ensure that the fitting is of rigid construction (especially at the point where the ballast is fitted)
- In large fittings the ballast should be separated from the fitting by mounting it on an aluminium plate (approx. 2 mm thick)
- Mount as few ballasts as possible in one fitting
- If using multiple ballasts in a fitting, ensure that the ballasts are mounted as far as possible from each other

Site considerations

Mixed technology on the same electrical circuit

- Magnetic and electronic ballasts should not be connected to the same electrical circuit. The energy spikes produced by magnetic ballasts may result in damage to the electronic ballasts

Miniature Circuit Breakers

- 'Type C' MCB's having trip characteristics in accordance with EN 60898 are recommended.
- 'Type B' MCB's are not recommended due to their sensitivity. If used, they must only be loaded to 60 % of the equivalent 'Type C' MCB

Type C MCB's are strongly recommended to use with fluorescent lighting.

- Other types can prove unsuitable due to their tripping properties.
- Practical quantities will depend strongly on the reactance of the actual circuit.

Conversion table for other types of Miniature Circuit Breaker

MCB type	Relative quantity of ballasts
B 10 A	37 %
B 16 A	60 %
B 20 A	75 %
C 10 A	62 %
C 16 A	100 % (see tables)
C 20 A	125 %

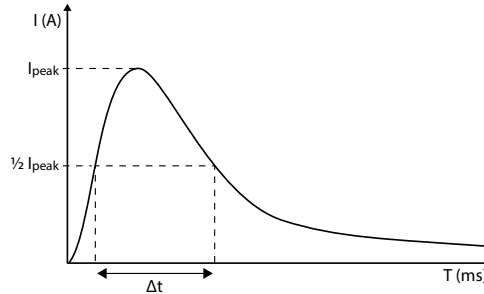

EL-iDim

Lamp(s)	iDim	Quantity of ballasts per miniature circuit breaker 16 A Type C		Typical inrush current I_{peak} (A)	1/2 value time Δt (μs)	Calculated energy $I_{peak}^2 \Delta t$ (A ² s)
		Based on I_{Cont}	Based on I_{peak}			
1x14 T5	EL 1x14-35iDim	152	46	35	144,0	0,13
2x14 T5	EL 2x14-35iDim	79	38	38	173,0	0,18
4x14 T5	EL 4x14iDim	42	42	35	141,0	0,13
1x21 T5	EL 1x14-35iDim	110	46	35	144,0	0,13
2x21 T5	EL 2x14-35iDim	56	38	38	173,0	0,18
1x24 T5, TC-L	EL 1x24iDim	101	57	30	123,0	0,08
2x24 T5, TC-L	EL 2x24iDim	51	45	37	130,0	0,13
1x28 T5	EL 1x14-35iDim	81	46	35	144,0	0,13
2x28 T5	EL 2x14-35iDim	42	38	38	173,0	0,18
1x35 T5	EL 1x14-35iDim	66	46	35	144,0	0,13
2x35 T5	EL 2x14-35iDim	34	34	38	173,0	0,18
1x36 T8, TC-L	EL 1x36iDim	73	45	37	130,0	0,13
2x36 T8, TC-L	EL 2x36iDim	37	34	44	165,0	0,23
1x39 T5	EL 1x39iDim	61	45	37	130,0	0,13
2x39 T5	EL 2x39iDim	31	31	44	165,0	0,23
1x49 T5	EL 1x49iDim	47	45	37	130,0	0,13
2x49 T5	EL 2x49iDim	24	24	49	200,0	0,36
1x54 T5	EL 1x54iDim	44	44	37	130,0	0,13
2x54 T5	EL 2x54iDim	22	22	49	200,0	0,36
1x55 T5, TC-L	EL 1x55iDim	43	43	37	130,0	0,13
2x55 T5, TC-L	EL 2x55iDim	22	22	49	200,0	0,36
1x80 T5, TC-L	EL 1x80iDim	30	26	49	200,0	0,36
3x14 T5	EL3x14iDim	54	48	34	141,0	0,12
2x80 T5, TC-L	EL2x80iDim	16	12	49	323,0	0,46

EL-iDim-c

Lamp(s)	iDim-c	Quantity of ballasts per miniature circuit breaker 16 A Type C		Typical inrush current I_{peak} (A)	1/2 value time Δt (μs)	Calculated energy $I_{peak}^2 \Delta t$ (A ² s)
		Based on I_{Cont}	Based on I_{peak}			
1x18 W TC-DE/TE	1/2x18iDim-c	119	56	26	171,0	0,08
2x18 W TC-DE/TE	1/2x18iDim-c	63	56	26	171,0	0,08
1x18 W TC-L/F	1/2x18/24iDim-c	107	56	26	171,0	0,08
1x24 W TC-L/F	1/2x18/24iDim-c	82	56	26	171,0	0,08
1x22 W TC-T5c	1/2x18/24iDim-c	82	56	26	171,0	0,08
1x40 W TC-T5c	1/2x18/24iDim-c	57	56	26	171,0	0,08
2x18 W TC-L/F	1/2x18/24iDim-c	67	56	26	171,0	0,08
2x24 W TC-L/F	1/2x18/24iDim-c	47	47	26	171,0	0,08
1x26 W TC-DE/TE	1/2x26-42iDim-c	82	56	26	171,0	0,08
1x32 W TC-TE	1/2x26-42iDim-c	67	56	26	171,0	0,08
1x42 W TC-TE	1/2x26-42iDim-c	54	54	26	171,0	0,08
2x26 W TC-DE/TE	1/2x26-42iDim-c	43	43	26	171,0	0,08
2x26 W TC-DE/TE	2x26-42iDim-c	47	26	49	200,0	0,36
2x32 W TC-TE	2x26-42iDim-c	37	26	49	200,0	0,36
2x42 W TC-TE	2x26-42iDim-c	28	26	49	200,0	0,36

EL-sc

Lamp(s)	EL-sc	Quantity of ballasts per miniature circuit breaker 16 A Type C		Typical inrush current I_{peak} (A)	1/2 value time Δt (μs)	Calculated energy $I_{peak}^2 \Delta t$ (A ² s)
		Based on I_{Cont}	Based on I_{peak}			
1 x 14 W T5	EL1x14sc	152	86	25	49	0.26
2 x 14 W T5	EL2x14sc	83	71	31	44	0.35
4 x 14 W T5	EL4x14sc	42	42	31	44	0.35
1 x 21 W T5	EL1x21sc	107	86	25	49	0.26
2 x 21 W T5	EL2x21sc	56	56	31	44	0.35
1 x 24 W T5	EL1x24sc	99	86	25	49	0.26
2 x 24 W T5	EL2x24sc	52	52	31	44	0.35
1 x 28 W T5	EL1x28sc	83	83	25	49	0.26
2 x 28 W T5	EL2x28sc	40	40	31	44	0.35
1 x 35 W T5	EL1x35sc	66	66	31	44	0.35
2 x 35 W T5	EL2x35sc	33	33	47	149	2.43
1 x 39 W T5	EL1x39sc	61	61	31	44	0.35
2 x 39 W T5	EL2x39sc	31	31	47	149	2.43
1 x 49 W T5	EL1x49sc	48	48	31	44	0.35
2 x 49 W T5	EL2x49sc	24	24	47	205	3.37
1 x 54 W T5	EL1x54sc	43	43	31	44	0.35
2 x 54 W T5	EL2x54sc	22	22	47	205	3.37
1 x 80 W T5	EL1x80sc	29	27	47	205	3.37
1 x 18 W T8	EL1x18sc	136	86	25	49	0.26
2 x 18 W T8	EL2x18sc	70	70	31	44	0.35
4 x 18 W T8	EL4x18sc	36	34	47	149	2.43
1 x 24 W TCL	EL1x24sc	99	86	25	49	0.26
2 x 24 W TCL	EL2x24sc	52	52	31	44	0.35
1 x 36 W T8/TCL	EL1x36sc	70	70	31	44	0.35
2 x 36 W T8/TCL	EL2x36sc	36	34	47	149	2.43
1 x 58 W T8	EL1x58sc	47	47	31	44	0.35
2 x 58 W T8	EL2x58sc	24	24	47	205	3.37
1 x 70 W T8	EL1x70sc	40	34	47	149	2.43
1 x 55 W TCL	EL1x55sc	42	42	31	44	0.35
2 x 55 W TCL	EL2x55sc	22	22	47	205	3.37
1 x 80 W TCL	EL1x80sc	29	27	47	205	3.37

EL-ngn5

Lamp(s)	EL-ngn5	Quantity of ballasts per miniature circuit breaker 16 A Type C		Typical inrush current I_{peak} (A)	1/2 value time Δt (μ s)	Calculated energy $I_{peak}^2 \Delta t$ (A ² s)
		Based on I_{cont}	Based on I_{peak}			
1x14 W T5	EL1x14-35ngn5	161	88	21	139	0.04
2x14 W T5	EL2x14-35ngn5	83	50	34	152	0.13
3x14 W T5	EL3/4x14ngn5	56	50	34	149	1.3
4x14 W T5	EL3/4x14ngn5	42	50	34	149	1.3
4x14 W T5	EL4x14ngn5	41	50	34	152	0,13
1x21 W T5	EL1x14-35ngn5	112	88	21	139	0.04
2x21 W T5	EL2x14-35ngn5	57	50	34	152	0.13
1x24 W T5	EL1x24ngn5	101	88	21	136	0.04
2x24 W T5	EL2x24ngn5	53	80	22	142	0.05
3x24 W T5	EL3/4x24ngn5	35	33	47	165	2.67
4x24 W T5	EL3/4x24ngn5	27	33	47	165	2.67
1x28 W T5	EL1x14-35ngn5	86	88	21	139	0.04
2x28 W T5	EL2x14-35ngn5	43	50	34	152	0.13
1x35 W T5	EL1x14-35ngn5	68	88	21	139	0.04
2x35 W T5	EL2x14-35ngn5	34	50	34	152	0.13
1x36 W T5	EL1x39/36ngn5	70	88	21	136	0.04
2x36 W T5	EL2x39/36ngn5	37	50	34	152	0.13
1x39 W T5	EL1x39ngn5	60	88	21	136	0.04
2x39 W T5	EL2x39/36ngn5	32	50	34	152	0.13
1x49 W T5	EL1x49ngn5	47	57	23	183	0.07
2x49 W T5	EL2x49ngn5	25	33	40	183	0.22
1x54 W T5	EL1x54ngn5	44	80	23	141	0.05
2x54 W T5	EL2x54ngn5	22	26	40	230	0.27
1x55 W T5	EL1x55ngn5	43	57	23	183	0.07
2x55 W T5	EL2x55ngn5	22	26	40	230	0.27
1x80 W T5	EL1x80ngn5	30	45	36	156	0.15
2x80 W T5	EL2x80ngn5	15	16	49	287	0,40

EL-ngn

Lamp(s)	EL-ngn (T8)	Quantity of ballasts per miniature circuit breaker		Typical inrush current I_{peak} (A)	1/2 value time Δt (μ s)	Calculated energy $I_{peak}^2 \Delta t$ (A ² s)
		Based on power consumption	Based on inrush current			
				C 16A	C 16A	
1x18	EL1x18ngn	136	85	23	131	0,05
2x18	EL2x18ngn	70	87	22	132	0,05
4x18	EL4x18ngn	36	32	37	193	0,20
1x36	EL1x36ngn	72	80	24	134	0,06
2x36	EL2x36ngn	37	56	30	152	0,09
1x58	EL1x58ngn	47	84	23	128	0,05
2x58	EL2x58ngn	24	37	50	136	0,26
3x18	EL3/4x18ngn	50	50	34	149	0,13
4x18	EL3/4x18ngn	37	50	34	149	0,13
1x15	EL1x15ngn	152	88	21	139	0,04
1x30	EL1x30ngn	92	88	21	139	0,04

EL-es

Lamp(s)	EL-es (T8)	Quantity of ballasts per miniature circuit breaker 16 A Type C		Typical peak inrush current I_{peak} [A]	1/2 value time r_t [μ s]	Calculated energy $I_{peak}^2 r_t$ [A ² s]
		Based on power consumption	Based on inrush current			
				C 16A	C 16A	
4x18	EL4x18es	35	60	29	148	0,09
2x36	EL2x36es	38	58	29	153	0,09
2x58	EL2x58es	24	29	37	215	0,21

EL-s / EL-su

Lamp(s)	EL-s	EL-su	Quantity of ballasts per miniature circuit breaker 16 A Type C		Typical inrush current I_{peak} (A)	1/2 value time Δt (μ s)	Calculated energy $I_{peak}^2 \Delta t$ (A ² s)
			Based on I_{Cont}	Based on I_{peak}			
2 x 58 W T8	EL2x58s	EL2x58s-u	24	24	47	165	2.67
1 x 70 W T8	EL1x70s	-	40	40	34	149	1.30
2 x 70 W T8	EL2x70s	-	20	20	49	180	3.17

EL-TCs

Lamp(s)	EL1/2x-TCs	Quantity of ballasts per miniature circuit breaker 16 A Type C		Typical inrush current I_{peak} (A)	1/2 value time Δt (μ s)	Calculated energy $I_{peak}^2 \Delta t$ (A ² s)
		Based on I_{Cont}	Based on I_{peak}			
1 x 9 W TC-SE	1/2x9-13TCs	229	34	41	182	0.23
1 x 10 W TC-DE	1/2x9-13TCs	224	34	41	182	0.23
1 x 10 W TC-DD	1/2x9-13TCs	215	34	41	182	0.23
1 x 11 W TC-SE	1/2x9-13TCs	167	34	41	182	0.23
1 x 13 W TC-DE/TE	1/2x9-13TCs	160	34	41	182	0.23
1 x 16 W TC-DD	1/2x9-13TCs	160	34	41	182	0.23
2 x 9 W TC-SE	1/2x9-13TCs	129	34	41	182	0.23
2 x 10 W TC-DE	1/2x9-13TCs	120	34	41	182	0.23
2 x 11 W TC-SE	1/2x9-13TCs	90	34	41	182	0.23
2 x 13 W TC-DE/TE	1/2x9-13TCs	84	34	41	182	0.23
1 x 18 W TC-DE/TE	1/2x18TCs	127	35	41	181	0.22
2 x 18 W TC-DE/TE	1/2x18TCs	67	35	41	181	0.22
1 x 21 W TC-DD	1/2x18TCs	102	35	41	181	0.22
1 x 18 W TC-L/F	1/2x18-42TCs	147	33	40	192	0.23
1 x 24 W TC-L/F	1/2x18-42TCs	96	33	40	192	0.23
1 x 26 W TC-DE/TE	1/2x18-42TCs	88	33	40	192	0.23
1 x 32 W TC-TE	1/2x18-42TCs	75	33	40	192	0.23
1 x 42 W TC-TE	1/2x18-42TCs	55	33	40	192	0.23
1 x 22 W TC-T5c	1/2x18-42TCs	96	33	40	192	0.23
1 x 40 W TC-T5c	1/2x18-42TCs	59	33	40	192	0.23
2 x 18 W TC-L/F	1/2x18-42TCs	68	33	40	192	0.23
2 x 24 W TC-L/F	1/2x18-42TCs	46	33	40	192	0.23
2 x 26 W TC-DE/TE	1/2x18-42TCs	42	33	40	192	0.23
2 x 26 W TC-DE/TE	2x32/42TCs	45	33	42	184	0.24
2 x 32 W TC-TE	2x32/42TCs	38	33	42	184	0.24
2 x 42 W TC-TE	2x32/42TCs	28	28	42	184	0.24
22 + 40 W TC-T5c	2x32/42TCs	38	33	42	184	0.24
40 + 40 W TC-T5c	2x32/42TCs	32	32	42	184	0.24
1x14W PL-R	1/2x14-17TCs	133	33	41	190	0.25
2x14W PL-R	1/2x14-17TCs	76	33	41	190	0.25
1x17W PL-R	1/2x14-17TCs	110	33	41	190	0.25
2x17W PL-R	1/2x14-17TCs	60	33	41	190	0.25
1x36TC-L	1/2x36/38TCs	63	33	42	184	0.24
2x36TC-L	1/2x36/38TCs	33	33	42	184	0.24
1x38TC-DD	1/2x36/38TCs	62	33	42	184	0.24
2x38TC-DD	1/2x36/38TCs	32	32	42	184	0.24

These instructions provide details of how to remove wires from the terminals of Helvar ballasts without damaging the terminals. Ensure mains supply is switched off before attempting any wire removal.

Electronic Ballasts quick release vertical push-in terminals

Use a blunt tool (example shown) to push down gently on the built in push button.

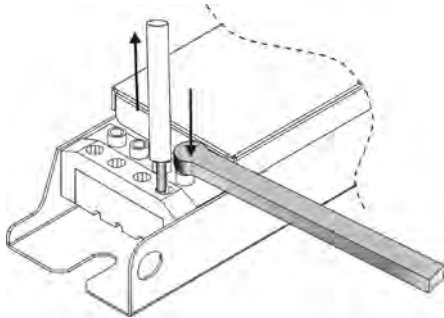

Note: Removal using a solid pin is not advised since permanent damage to the connector may occur.

IDC & horizontal push-in terminals)

Gently twist and pull wire at the same time

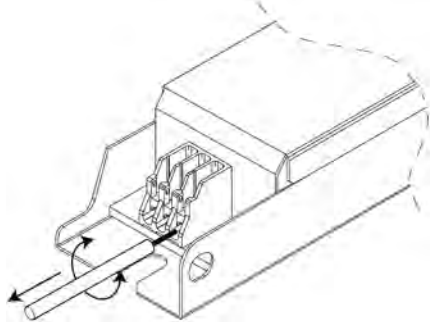

Note: Wire removal from insulation piercing contact is only possible with force.

EL-ngn

Use a 1 mm² solid pin (or similar) or gently twist and pull wire at the same time

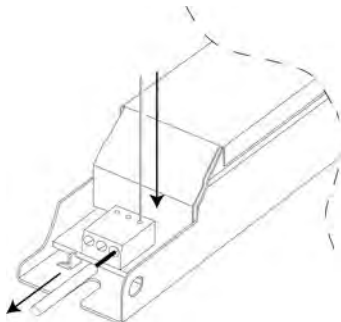

Magnetic Ballasts ... with push in terminals

Use a 1 mm² solid pin (or similar)

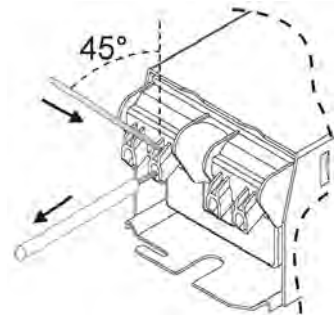
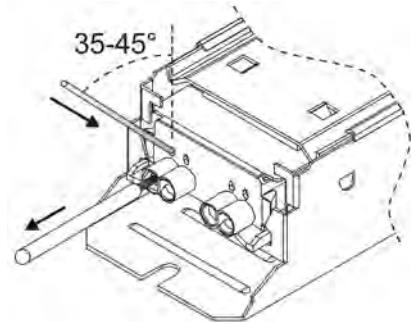

... NK/E...SE & L26S types

Use a flat blade screwdriver

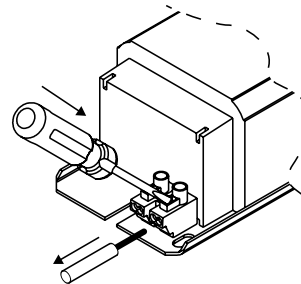

... with screw terminals

Use a flat blade screwdriver

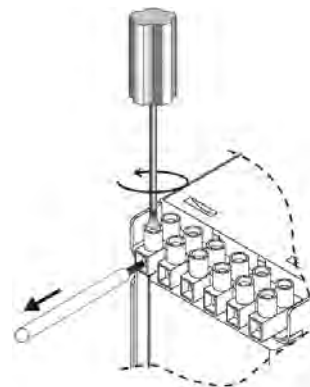

Helvar ballasts for fluorescent lamps

Lamp type	W	Length (mm)	Cap	Standard electronic ballast	Page	Controllable electronic ballast	Page	Digital DALI electronic ballast	Page	Magnetic Ballast (230 V, 50 Hz)	Page
T5 (FD-H) ø16mm	4	136	G5							L 8 D L 8 DL ¹⁾	38
	6	212	G5							L 8 D L 8 DL ¹⁾	38
	8	288	G5	EL1/2x9-13TCs ²⁾	-					L 8 D L 11 D	38
	13	517	G5		-					L 13 DL ¹⁾	38
	14	549	G5	EL1x14-35ngn5 EL2x14-35ngn5 EL3/4x14ngn5 EL4x14ngn5 EL1/2x9-13TCs	20 27	EL1x14sc EL2x14sc EL4x14sc	10	EL1x14-35iDim EL2x14-35iDim EL3x14iDim EL4x14iDim	6		
	21	849	G5	EL1x14-35ngn5 EL2x14-35ngn5 EL1/2x9-13TCs	20 27	EL1x21sc EL2x21sc	10	EL1x14-35iDim EL2x14-35iDim	6		
	24	549	G5	EL1x24ngn5 EL2x24ngn5 EL3/4x24ngn5	20	EL1x24sc EL2x24sc	10	EL1x24iDim EL2x24iDim	6		
	28	1149	G5	EL1x14-35ngn5 EL2x14-35ngn5 EL1/2x9-13TCs	20 27	EL1x28sc EL2x28sc	10	EL1x14-35iDim EL2x14-35iDim	6		
	35	1449	G5	EL1x14-35ngn5 EL2x14-35ngn5	20	EL1x35sc EL2x35sc	10	EL1x14-35iDim EL2x14-35iDim	6		
	39	849	G5	EL1x39/36ngn5 EL2x39/36ngn5	20	EL1x39sc EL2x39sc	10	EL1x39iDim EL2x39iDim	6		
	49	1449	G5	EL1x49ngn5 EL2x49ngn5 EL2x49ngn5-XL	20	EL1x49sc EL2x49sc	10	EL1x49iDim EL2x49iDim	6		
	54	1149	G5	EL1x54ngn5 EL2x54ngn5 EL2x54ngn5-XL	20	EL1x54sc EL2x54sc	10	EL1x54iDim EL2x54iDim	6		
	80	1449	G5	EL1x80ngn5 EL2x80ngn5	20	EL1x80sc	10	EL1x80iDim EL2x80iDim	6		



Types printed **BOLD** are ENEC approved combinations. Other combinations mentioned are tested and recommended by Helvar.

Please check CE compatibility and EEL classification from ballast datasheets.

For information on compatibility with amalgam lamps, please contact your local Helvar representative.

1) Approved to EN 61347-2-8

2) For a combination of two 8 W T5-lamps

Note: All combinations can be used as well with Eco-lamps.

Helvar ballasts for fluorescent lamps

Lamp type	W	Length (mm)	Cap	Standard electronic ballast	Page	Controllable electronic ballast	Page	Digital DALI electronic ballast	Page	Magnetic Ballast (230 V, 50 Hz)	Page
T8 (FD-E) ø 26 mm 	18	590	G13	EL1x18ef EL2x18ef EL4x18ef EL4x18es	23	EL1x18sc EL2x18sc EL4x18sc	12			L 18 A-L L 18 A-K L 18 A-T L 2x18 A-L L 2x18 A-L	35
				EL1x18ngn EL2x18ngn EL3/4x18ngn EL4x18ngn	22						
	36	1200	G13	EL2x36es EL1x36ef EL2x36ef	23	EL1x36sc EL2x36sc	12	EL1x36iDim EL2x36iDim	8	L 36 A-T L 36 A-K L 40 A-C L 36 LUA	35
				EL1x36ngn EL2x36ngn EL1x18-42TCs	22						
	58	1500	G13	EL2x58es EL1x58ef	23	EL1x58sc EL2x58sc	12			L 65 A-P L 58 A-K L 58 A-T L 58 LUA	35
				EL1x58ngn EL2x58ngn	22						
	70	1500	G13	EL1x70s EL2x70s	23	EL1x70sc	12			L 75 A-S ²⁾ L 75 LUA	35
	15	450	G13		-		-			L 15 A L 15 A-P	35
	16	720	G13		-		-			L 16 D L 16 DL	35
	23	970	G13		-		-			L 15 A-P	35
30	900	G13	EL2x32/42TCs	27					L 30 A L 30 A-P	35	
38	1047	G13		-	EL1x36sc EL2x36sc	-			L 36 A-K L 36 A-T L 36 LUA L 40 A-C	35	

Types printed **BOLD** are ENEC approved combinations. Other combinations mentioned are tested and recommended by Helvar.



Please check CE compatibility and EEL classification from ballast datasheets.

1) Approved to EN 61347-2-8

2) 240 V, 50 Hz

3) Not T8 eco lamp

Helvar ballasts for fluorescent lamps

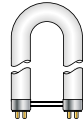
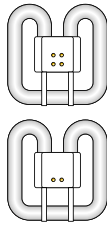
Lamp type	W	Cap	Standard electronic ballast	Page	Controllable electronic ballast	Page	Digital DALI electronic ballast	Page	Magnetic Ballast (230 V, 50 Hz)	Page
T5 circular 	22	2GX13	EL1/2x18-42TCs	27			EL1/2x18/24iDim-c	9		
	40	2GX13	EL1/2x18-42TCs EL2x32/42TCs¹⁾	27	EL1x39sc EL2x39sc	13 -	EL1/2x18/24iDim-c	9		
	55	2GX13	EL1x55ngn5	-	EL1x55sc	-				
Circline (FD-E) 	22	G10q							L 30 A	38
	32	G10q								
	40	G10q							L 36 A-K L 36 A-T L 36 LUA L 40 A-C	-
Mod-U-line (FU-E) 	40	G13		-					L 36 LUA L 40 A-C L 36 A-K L 36 A-T	-
TC-DD 2D-lamp GR8, for magnetic ballast only GR10q, for electronic ballast or magnetic with external starter 	10	GR10q	EL1/2x9-13TCs	27						
	16	GR8, GR10q	EL1/2x9-13TCs	27					L 16 D²⁾ L 16 DL	38
	21	GR8, GR10q	EL1/2x18-42TCs							
	28	GR8, GR10q	EL1/2x18-42TCs	27					L 18 A-L L 18 A-T L 18 A-K L 26S	38
	38	GR8, GR10q	EL1/2x36/38TCs	27					L 36 LUA L 40 A-C L 36 A-K L 36 A-T	38

Types printed **BOLD** are ENEC approved combinations. Other combinations mentioned are tested and recommended by Helvar.

Please check CE compatibility and EEL classification from ballast datasheets.

For information on compatibility with amalgam lamps, please contact your local Helvar representative.

1) For a combination of one 22 W and one 40 W circular lamp

2) GR8 not ENEC approved





Lamp type	W	Cap	Standard electronic ballast	Page	Controllable electronic ballast	Page	Digital DALI electronic ballast	Page	Magnetic Ballast (230 V, 50 Hz)	Page
TC-L (FSD-E) 	18	2G11	EL1/2x18-42TCs EL1x36/40/18s	26 25		-	EL1/2x18/24iDim-c	9	L18 A-K L18 A-T L18 A-L	37
	24	2G11	EL1/2x18-42TCs EL1x24ngn5 EL2x24ngn5 EL3/4x24xngn5	26 24	EL1x24sc EL2x24sc	13	EL1x24iDim EL2x24iDim EL1/2x18/24iDim-c	8 9	L18 A-K L18 A-T L18 A-L	37
	26	2GX11					EL1x14-35iDim ¹⁾ EL2x14-35iDim ¹⁾	8		
	28	2GX11					EL1x14-35iDim ¹⁾ EL2x14-35iDim ¹⁾	8		
	36	2G11	EL1x39/36ngn5 EL2x39/36ngn5 EL1/2x36/38TCs EL1/2x18-42TCs EL2x36ngn	24 28 26 -	EL1x36sc EL2x36sc	13	EL1x36iDim EL2x36iDim	8	L 36 LUA L 40 A-C L 36 A-T L 36 A-K	37
	40	2G11	EL1/2x18-42TCs	26	EL1x39sc EL2x39sc	13	EL1x39iDim EL2x39iDim	8		
	55	2G11	EL1x55ngn5 EL2x55ngn5	24	EL1x55sc EL2x55sc	13	EL1x55iDim EL2x55iDim	8		
	80	2G11	EL1x80ngn5 EL2x80ngn5	24	EL1x80sc	13	EL1x80iDim EL2x80iDim	8		

Types printed **BOLD** are ENEC approved combinations. Other combinations mentioned are tested and recommended by Helvar. Please check CE compatibility and EEL classification from ballast datasheets.

For information on compatibility with amalgam lamps, please contact your local Helvar representative.

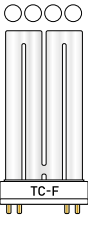
1) To ensure stable operation of the lamp it is not recommended to dim the light level below 3 %

Helvar ballasts for fluorescent lamps



Lamp type	ILCOS	W	Cap	Standard electronic ballast	Page	Controllable electronic ballast	Page	Digital DALI electronic ballast	Page	Magnetic Ballast (230 V, 50 Hz)	Page
TC-F 	FSS-E	18	2G10	EL1/2x18-42TCs	26			EL1/2x18/24iDim-c	9	L 18 A-L L 18 A-K L 18 A-T	-
		24	2G10	EL1/2x18-42TCs	26	EL1x24sc EL2x24sc	13	EL1/2x18/24iDim-c	9	L 18 A-L L 18 A-T L 18 A-K	-
		36	2G10	EL1/2x36/38TCs EL1/2x18-42TCs EL1x39/36ngn5 EL2x39/36ngn5	26 26 -	EL1x36sc EL2x36sc	13	EL1x36iDim EL2x36iDim	-	L 36 A-K L 36 LUA L 40 A-C	-
TC-S 	FSD-I	5	G23							L 11 D	37
		7	G23							L 11 D	37
		9	G23							L 11 D	37
		11	G23							L 11 D	37
TC-SE 	FSD-E	9	2G7	EL1/2x9-13TCs	26						
		11	2G7	EL1/2x9-13TCs	26						
TC-D 	FSQ-I	10	G24d-1							L 13 D L13 DL ¹⁾	38
		13	G24d-1							L13 D L13 DL ¹⁾	38
		18	G24d-2							L18 D L18 DL	38
		26	G24d-3							L26 S-100mm L18 A-L L18 A-K L18 A-T	38

Types printed **BOLD** are ENEC approved combinations. Other combinations mentioned are tested and recommended by Helvar.

Please check CE compatibility and EEL classification from ballast datasheets.

For information on compatibility with amalgam lamps, please contact your local Helvar representative.

1) Approved to EN61347-2-8

Lamp type	ILCOS	W	Cap	Standard electronic ballast	Page	Controllable electronic ballast	Page	Digital DALI electronic ballast	Page	Magnetic Ballast (230 V, 50 Hz)	Page
TC-DE 	FSQ-E	10	G24q-1	EL1/2x9-13TCs	28						
		13	G24q-1	EL1/2x9-13TCs	28						
		18	G24q-2	EL1/2x18TCs	28			EL1/2x18iDim-c	9		
		26	G24q-3	EL1/2x18-42TCs EL2x32/42TCs	28			EL1/2x26-42iDim-c EL2x26-42iDim-c	9		
TC-T 	FSM-I	18	GX24d-2							L18 D	-
		26	GX24d-3							L18 TL2 L18 TL3	- -
TC-TE 	FSM-E	13	GX24q-1	EL1/2x9-13TCs	28						
		18	GX24q-2	EL1/2x18TCs	28			EL1/2x18iDim-c	9		
		26	GX24q-3	EL1/2x18-42TCs EL2x32/42TCs	28			EL1/2x26-42iDim-c EL2x26-42iDim-c	9		
		32	GX24q-3	EL1/2x18-42TCs EL2x32/42TCs	28			EL1/2x26-42iDim-c EL2x26-42iDim-c	9		
		42	GX24q-4	EL1/2x18-42TCs EL2x32/42TCs	28			EL1/2x26-42iDim-c EL2x26-42iDim-c	9		
		57	GX24q-4	EL1/2x18-42TCs	28			EL1/2x26-42iDim-c ²⁾	9		
PL-R		14	GR14q-1	EL1/2x14/17TCs	27						
		17	GR14q-1	EL1/2x14/17TCs	27						

Types printed **BOLD** are ENEC approved combinations. Other combinations mentioned are tested and recommended by Helvar.

Please check CE compatibility and EEI classification from ballast datasheets.

1) Approved to EN61347-2-8

2) $U_{IN} > 220 V$, $T_a > 18^{\circ}C$

For information on compatibility with amalgam lamps, please contact your local Helvar representative.

Helvar



www.helvar.com

Helvar has representatives all over the world.
For additional information, please visit www.helvar.com

Due to a policy of continuous improvement, Helvar reserve the right to alter specifications without notice at anytime.

Каталог с Profsector.com